

Gas Quality Analyzer
GasLab Q2



Operating Instructions



Document history

Version	Date	Author	Changes
a to g	June 21, 2016 until June 06, 2017	Gas Quality	For software version 03-03-B to 03-08 A in test- and pre-production samples
h	June 09, 2017	Gas Quality	1rst version (ATEX and FM) for worldwide use - extension I/O configuration and service calibration
	June 21, 2017		Translation correction

Copyright

©2017 Elster GmbH All rights reserved.
GasLab Q2® is a registered trademark of Elster GmbH.

Only operating instructions published by the Elster GmbH are to be used. Changes or translations of these Operating Instructions require the written consent of the Elster GmbH. All obligations of the Elster GmbH arise solely from the agreement concluded and the applicable General Terms and Conditions upon conclusion of the agreement.

Warranty conditions

Our current warranty conditions as in the General Terms and Conditions are published on our website: www.elster-instromet.com/en/general-terms-of-business

Contact

Elster GmbH (Manufacturer)
Steinern Str. 19-21
55252 Mainz-Kastel / Germany

Phone: +49 6134 605 0
E-mail: Info@elster.com
Website: www.elster-instromet.com

Technical Assistance Center:
Phone: +49 231 93 71 10 88
E-mail: ElsterSupport@Honeywell.com
Website: www.elster-instromet.com

Contents

1	About these Operating Instructions	7
1.1	Symbols and terms	7
1.2	Notes on using these Operating Instructions	9
1.3	Technical advice and repairs	9
2	Safety information and warnings	10
2.1	Intended use	10
2.1.1	Special conditions of use for FM approvals	11
2.2	Qualified hardware persons	11
2.3	General safety notes	11
2.4	Instructions and warnings on the housing of Q2	13
2.5	Safety information about: Application / gases / ambient conditions	13
2.6	Electrical safety information	15
2.7	Risk of explosion / explosive range / protection of explosions	17
2.8	Responsibility of the operator	18
3	Measurement concept of GasLab Q2	19
3.1	Description of main features	19
3.2	Description of the operating principle	20
3.3	System setup	22
4	Structure of GasLab Q2	23
4.1	Instrumentation area	24
4.2	Connection area	26
4.2.1	Gas connections and breathing element (breather)	26
4.2.2	Electrical entries and connections	27
4.3	Human machine interface (HMI)	29
5	Transport, storage, installation	30
5.1	Transportation / storage	30
5.2	Mechanical installation of GasLab Q2	31
5.2.1	Location of use and installation	31
5.2.2	GasLab Q2 dimensions	33
5.2.3	Dismantling	33
5.3	Fluidic installation of GasLab Q2	34
5.3.1	Gas connections	34
5.3.2	Connecting gas lines (general)	35
5.3.3	Preparing the process gas connection	36
5.3.4	Connecting or replacing gas cylinders	37
5.3.5	Connecting the exhaust tubing	39
5.3.6	Connect Q2 to the processgasline and completethe fluidic installation	40
5.3.7	Leak test of the installation	41
5.4	Electrical installation	41
5.4.1	Power supply / electric protection / grounding	42
5.4.2	Cables and electrical entries (power supply and communication)	44
5.4.3	Electrical connection plan and electrical interfaces (outputs and inputs)	45
5.4.4	Connection to other devices and parts of the plant	47

6	Commissioning and decommissioning	51
6.1	Requirements for commissioning and operation	51
6.2	Start-up and normal operation	52
6.2.1	Checking and customizing the gas flows	53
6.2.2	Checking device settings and signals	53
6.3	Decommissioning	54
7	GasLab Q2 displays and operating the device	55
7.1	Concept of the operation panel	56
7.1.1	Local and remote operation	56
7.1.2	Navigation in operation panels and displays	57
7.2	Displays of the GasLab Q2	61
7.2.1	Home (display overview / device language / start-up-errors)	61
7.2.2	Display Info Q2 (System)	64
7.2.3	Error list main display	67
7.2.4	Display sensor values	68
7.2.5	Display Control (calibration / verification / touch)	69
7.2.6	Display system (device) (time / user / logbook)	70
7.2.7	Q2 Main display (calculation standard)	76
7.2.8	Display Archive and Display Modbus	80
7.3	Operation and modes	81
7.3.1	Monitoring of the devices functions and the security switch	81
7.3.2	Operation mode: Analysis (automatic analysis normal operation)	82
7.3.3	Operation mode: Operational calibration (manual)	82
7.3.4	Operation mode: Verification (special operation)	84
7.3.5	Entries and changes via device displays	86
7.3.6	Log in, log out, and change password at operation panel	88
7.3.7	View into logbooks	91
7.3.8	Change IP address and basic network settings at device	93
7.3.9	Update the system time on the device	94
7.4	Announcement of events	95
7.4.1	LEDs over the interactive display	95
7.4.2	View event-related display texts in the error list	96
7.4.3	List of event-related display texts	96
7.4.4	Accept and removal of event-related display texts	100
7.4.5	Other possible error events during normal operation (troubleshooting)	100
8	Operation and parameter setting on the PC with enSuite	104
8.1	PC-Software concept of GasLab Q2	104
8.1.1	Installation and start of enSuite	105
8.1.2	Connection and disconnection with devices	106
8.1.3	Readout and watch parameterization (device settings)	107
8.1.4	Watch factory parameterization of the SFBs and AFBs	108
8.2	User management and login	109
8.2.1	View access rights	110
8.2.2	Restriction on Q2 relevant parameters (use virtual login)	110
8.3	Change existing device settings (parameterization)	111
8.3.1	Change device parameterization offline (offline parameterization)	112
8.3.2	Edit device parameterization in a connected device (online- parameterization)	115
8.3.3	Immutable preferences	116
8.3.4	Change automatic operational calibration	116
8.3.5	Reset all parameters to default condition	117

8.4	EnSuite during service operation	118
8.4.1	Customize displays	118
8.4.2	Update date and time with enSuite	119
8.4.3	Set time-related values and actions in the Time Service SFB	119
8.4.4	User profile management	119
8.4.5	Functions "Read out archives" and "Show archive"	121
8.4.6	Function "Live data and trending"	123
8.4.7	Use approval file (optional)	125
9	Maintenance and repair	126
9.1	Maintenance	126
9.2	Perform service calibration yourself.	127
9.3	Repair and Elster service work	129
10	Technical data and notes	131
10.1	Tables and information additional to the device	131
10.2	Inscriptions and hints on the device	134
10.2.1	Metering ranges and safety notes	134
10.2.2	Type plates	135
10.2.3	Extra additional markings	136
10.3	Declaration of Conformity	137
11	Appendix	138
11.1	Nomenclature	138
11.2	Definitions and explanations	139
12	Index	142
12.1	Keywords	142
12.2	Figures	147

1 About these Operating Instructions

This documentation describes the function, installation, commissioning, operation, use, and maintenance of the Honeywell Elster® GasLab Q2 Gas Quality Analyzer (hereinafter GasLab Q2 or just Q2). This device is used worldwide. Operating Instructions are available in German and English. Use the language that you are most familiar with to understand all the provided information. The safety and warning signs on the device are in English or French.

Within the scope of these Operating Instructions, the information is reproduced with additional information. Therefore, the security information is bilingual. If you need a manual or information in another language, please contact the Elster GmbH. The Operating Instructions are aimed at professionals in the field of the gas industry / process measuring technique and provides device-specific knowledge. In addition to general specialist knowledge, it enables safe and efficient handling of the instrument.



**Different basic skills are required depending on the field of activity.
Corresponding information can be found in the respective chapters.
The definitions used are listed ⇒ See chapter 11.2.**

**Selon le domaine d'activité, diverses compétences de base sont nécessaires.
Les informations correspondantes se trouvent dans les chapitres respectifs.
Les définitions utilisées se trouvent dans le chapitre 11.2.**

Compliance with all the safety notes and handling directions specified in these Operating Instructions is a requirement to work with the device in a safe manner, to use it properly and to obtain accurate measurement and calculation results. In addition, compliance is also required for the guidelines, standards, local accident prevention regulations, and general safety regulations that apply to the device's area of application.



The printed documentation attached to the device reflects the technical status at the time of delivery.

Subject to technical modifications in the course of further development. These will be introduced without notice in the latest version.











Download all operating instructions in PDF format from our DOCUTHEK (www.docuthek.com). The documents are updated regularly. Make sure that you use the correct document for your device.

The figures used to represent the issues discussed may vary slightly from the actual design.

1.1 Symbols and terms

The safety notes and warnings in these Operating Instructions and on the GasLab Q2 support the proper handling of the measurement device. The symbols and terms are defined below. Text that is preceded by such a sign must be observed.

Icon / symbol	Meaning / sens
	<p>indicates information that is important and relevant for the safety function. HAZARD MAPS like DANGER! / WARNING! / CAUTION! / ATTENTION! Indicate hazardous situations, which may result in material damage and bodily harm, or even death if disregarded.</p> <p>Indique les informations importantes et pertinentes pour l'exercice des fonctions et pour la sécurité. On retrouve aussi des mots comme: DANGER! / AVERTISSEMENT! / ATTENTION! qui attirent l'attention sur une situation à risque. Toute personne qui ne prend pas en compte ses avis de sécurité sera susceptible de subir des dommages matériels, des blessures et pourrait même mourir.</p>

Icon / symbol	Meaning / sens
 Explosion	<p>indicates that death and/or injury to persons can occur and additional significant damage to plant, equipment, and environment may arise if proper precautions are not taken.</p> <p>signifie qu'il y a un danger de mort et / ou de blessures pour plusieurs personnes et qu'il y a un danger que l'usine, l'équipement et l'environnement pourrait être gravement affecté si les précautions de sécurité appropriées ne sont pas respectées</p>
	<p>means that severe personal injury or damage to health can occur if proper precautions are not taken. Death is also possible.</p> <p>signifie qu'il y a un danger de blessures graves, d'atteinte à la santé et même de mort si les précautions de sécurité appropriées ne sont pas respectées.</p>
	<p>means that you may not perform or execute the following, unless the required terms and conditions are met and you are qualified to carry out the relevant work.</p> <p>signifie que vous ne pouvez pas exécuter ce qui suit, à moins que les conditions mentionnées soient réunies et que vous soyez qualifié pour le faire.</p>
	<p>Important information in the Operating Instructions: this symbol on the device reminds you to consider all matters that are mentioned in this document.</p> <p>Informations importantes dans le mode d'emploi, le symbole sur le produit est un rappel à suivre toutes les indications contenues dans ce document.</p>
$U = 24 V \text{ ---}$	<p>Means power supply of the device with 24 volts direct current</p> <p>Signifie que la source d'alimentation de l'appareil fonctionne en courant continu de 24 volts</p>
	<p>Indicating the main PE terminal (Protective earth)</p> <p>Signifie qu'il y a une borne de terre principale (conducteur de protection)</p>
	<p>Indicating the functional earth terminal (FE)</p> <p>Signifie qu'il y a une borne de terre fonctionnelle (FE)</p>
	<p>Identifies information that is interesting and useful for a particular topic, but does not apply to the safety.</p> <p>Indique les conseils et les recommandations qui sont d'intérêt et qui sont utiles , mais qui ne sont pas liées à la sécurité.</p>
ASTM 3588	<p>Links (hyperlink) You can navigate through different displays using the hyperlinks. In the example, you change the calculation standard; for more information, see chapter 7.</p> <p>Liens (hyperliens) : Par les hyperliens, vous pouvez naviguer vers différents éléments textuels. Dans cet exemple, le lien renvoie à une norme de calcul différente, voir le chapitre 7 pour plus d'informations.</p>
[OK] [F1]	<p>Markings on buttons and keys are additionally framed by square brackets.</p> <p>Les inscriptions des touches et des boutons sont également encadrées de crochets.</p>
	<p>Markings with messages (Alarm / Warning / Note) in enSuite (in most cases you can use the online help)</p> <p>Signe d'indication de message (Alarme / avertissement / avis) dans enSuite (dans la majeure partie des cas, vous pouvez utiliser l'aide en ligne)</p>
	<p>Signal markings (alarm / warning / information) in enSuite</p> <p>Signe d'identification du signal (alarme / avertissement / information) dans enSuite</p>
	<p>This triangle prompts you for an action</p> <p>Ce triangle vous invite à une action</p>

1.2 Notes on using these Operating Instructions

This documentation contains device-related safety information and warnings that must be observed to avoid personal injury and property damage. It also ensures safe and proper operation and must be strictly followed. To ensure comprehensive and integrated understanding of the measurement system, it is essential that you read the Operating Instructions before you carry out any work.



It shall suffice to read the respective chapter to gain knowledge about subsections, such as operation. The entire technical documentation should be on hand at all times.

The term "cable" is used always for electrical lines or wires to ensure a better distinction between gas and electric lines in this documentation.



General safety rules are assumed to be known and are not fully repeated here!

Les règles générales de sécurité sont considérés comme connues et ne sont donc pas énoncés en détail ici!

The safety notes and warnings (usually shown with an icon in a gray box like here) include notes and information that must be read and adhered to in any case!

Les conseils de sécurité et les 'avertissements (habituellement, comme ici représentés par une icône dans une zone grise) comprennent des commentaires et des informations qui doivent être lues et respectées dans tous les cas!

Compliance with the information and rules of these Operating Instructions ensures the safe functionality of the device, delivers reliable measurement results, extends the product life of the device and saves you money for service and the costs for spare parts. If you want to use additional equipment or devices in combination with the measurement device, please ensure that they are suitable components. These additions have their own Operating Instructions that you should also observe.



A missing symbol or a missing note does not release the specialist from his or her safety responsibilities.

Même si un signe ou un avertissement est manquant, le spécialiste reste responsable de sa sécurité!

1.3 Technical advice and repairs

If you have any questions or concerns arising from these Operating Instructions or concerning repairs, please contact our **Customer Service team**. The contact details can be found on page 3 of these Operating Instructions.



Elster GmbH is always interested in new information and experiences that result from the application and that may be useful to improve our products

2 Safety information and warnings

The safety notes and warnings in these Operating Instructions (and on the measurement device in English or French) support the proper handling of the device and how to avoid injury and damage. The device meets the relevant safety standards. If used appropriately, it poses no dangers that could threaten the health of personnel or cause damage to property.



Safety information and warnings must be read and adhered to for the safe and proper operation at all times! Necessary language skills are assumed.
Les conseils de sécurité et les mises en garde doivent être dans tous les cas lues et respectées pour assurer un fonctionnement sûr et adéquat! Les compétences linguistiques appropriées sont nécessaires.

Avoidable damage to the equipment resulting, for example, from insufficient knowledge of the Operating Instructions, shall lead to the loss of any liability claims against the Elster GmbH.
Les dommages qui peuvent être évités et qui résultent, par exemple, d'une connaissance insuffisante des instructions ne peuvent faire l'objet d'une réclamation de réparation de préjudice à la société 'Elster GmbH.

Missing warning symbols do not relieve individuals from their personal responsibility for safety!
Même si des avertissements de sécurité sont manquants, chacun reste responsable de sa sécurité. Avant-coureurs manquants ne libèrent pas de la responsabilité de la sécurité personnelle!



If it is determined that the measurement device or parts of the device, such as safety valves or inlet tubes, are damaged or no longer operate safely, the measuring device has to be taken out of operation, disconnected from the gas and electricity supply and secured from being placed into operation inadvertently.

Si on détermine que le compteur ou d'autres parties impliquées dans la mesure, par exemple, les soupapes de sûreté ou le tuyaux d'entrée sont endommagés ou ne fonctionnent plus sécuritairement, l'équipement doit être mis hors service et doit être débranché des sources de gaz et d'électricité. Il doit aussi être rangé de manière sécuritaire afin de s'assurer qu'il ne sera pas remis en service par inadvertance

2.1 Intended use

The GasLab Q2 is designed and constructed exclusively for its intended use. This is to analyze the gas composition of natural gas or natural material like gas as described later in this document (see chapter 3 and following). Intended use includes compliance with all specifications in these Operating Instructions or on the measurement device. Any use beyond the intended use or any other use of Q2 is considered misuse. Any claims for damages due to misuse are excluded.



The device is to be used only for its intended purpose as described in these Operating Instructions.
L'appareil ne doit être utilisé que pour son usage recommandé comme décrit dans le manuel d'instruction.



Use of the device for other tasks or purposes may impair the protection in place. This can lead to dangerous situations.

Si vous utilisez l'appareil pour d'autres tâches ou à des fins différentes de celles décrites, la sécurité de l'appareil ne peut être garantie. Cela peut conduire à des situations dangereuses.

2.1.1 Special conditions of use for FM approvals

In order to operate the device conforming to FM approvals, the following items must be considered:

1. Contact manufacturer for flameproof joint details if repair is required.
2. For painted models, the housing may only be cleaned with a moist / damp cloth because of potential static charging.

2.2 Qualified hardware persons



Mounting, electrical installation, commissioning, inspection and maintenance work (opening of the housing) may only be performed by qualified trained personnel or specialists.

Le montage, l'installation électrique, la mise en service, l'inspection et les travaux de maintenance (ouverture du boîtier) ne doivent être effectués que par du personnel qualifié ou spécialisé.

The qualified specialists must have expertise according to EN-IEC 60079-14 Annex A or comparable expertise. They must have the ability to recognize hazards and risks, assess their own work and avoid potential hazards.

Knowledge of these Operating Instructions, including in particular its safety and warning information, as well as the general safety rules, are essential prerequisites.



The station operator should carefully select qualified persons. Elster GmbH shall not be liable for damages and consequential damages, which result from the use of untrained personnel.

2.3 General safety notes



Warning! / Attention!

**A risk of explosion exists if the Q2 is incorrectly installed and connected!
Une installation et une connexion mal effectuées soumettent le Q2 à des risques d'explosion!**

- **The Q2 may only be installed in a hazardous area according to the listed approval on the device. Q2 GasLab peut être installé et utilisé uniquement dans la zone dangereuse spécifiée sur l'appareil.**
- **The preconditions of the relevant local / national standards (e.g. IEC EN 60079-14 installation of Ex equipment in Europe) must be followed. Les normes nationales et internationales pertinentes (par exemple IEC EN 60079-14 installation de l'équipement Ex), doivent être respectées.**

The following safety and warning notes must be observed unconditionally.
(If in doubt, please contact the Elster GmbH):



- **Any individual appointed to perform work on or with the Q2 must read and understand these Operating Instructions prior to the work.**
Tous ceux qui sont chargés d'effectuer des travaux sur ou avec la Q2 doivent connaître et avoir compris le contenu de ce manuel avant de commencer à travailler.
- **In order to avoid risks and to ensure that the Q2 performs in an optimal manner, no changes or modifications that were not expressly authorized by the Elster GmbH may be performed on it.** Pour éviter tout risque et pour s'assurer que le Q2 fonctionne de manière optimale, aucune modifications ou transformations n'ayant pas été expressément approuvés par la société Elster GmbH peuvent être effectuées.
- **The Q2 must not be exposed to temperatures below -25°C or above $+55^{\circ}\text{C}$ during storage and operation. This must be ensured.** Il faut veiller à ce que le Q2 ne soit pas exposé à des températures inférieures à -25°C et supérieures à $+55^{\circ}\text{C}$ lors du stockage et lors de son utilisation.
- **Any electrical equipment connected to the appliance must be insulated in a reinforced manner from the mains (electrical distribution)** Tout équipement électrique connecté à l'appareil doit être isolé de manière renforcée du réseau (de distribution électrique)
- **The electrical power supply (24 V DC fluctuation including mains fluctuation $\pm 15\%$) must have a reliable electrical isolation.** L'alimentation électrique 24 V DC (incl. les fluctuations électriques $\pm 15\%$) doit être muni d'une isolation électrique fiable.
- **The use of a PELV system is allowed.** Un système TBTS peut être utilisé.
- **Supply and communication (cables and wires not part of device) must be shielded and be conform to the local installation guidelines.** Les câbles pour l'alimentation et pour la communication (non fournis) doivent être blindés et doivent être conformes aux règles d'installation locales.
- **Use cables or wires and cable entries suitable for 10°C (10K) above the maximum ambient temperature.** Utiliser des câbles ou des fils et des entrées de câble appropriés qui supportent des températures au delà de 10°C (10K) au dessus de la température ambiante maximum.
- **The installer must ensure that the wiring is protected against overload and short circuit. Its power supply must be fused externally.** L'installateur doit veiller à ce que le câblage est protégé contre les surcharges et les courts-circuits. Leur tension d'alimentation doit être protégée à l'extérieur.
- **The connection for grounding on the bottom of the device has to be used under any circumstances.** La borne (mise à terre) situé au dessous de l'appareil doit être utiliser dans tous les cas.

2.4 Instructions and warnings on the housing of Q2



The information on the device must be always observed and followed! The operator must have sufficient language skills to understand their meaning! Les informations sur l'appareil doivent être respectées et suivies en tout temps! Il est nécessaire de disposer de compétences linguistiques suffisantes pour saisir leur sens!

On the device are warnings in English and / or French.

The type plate does not provide sufficient space, so there are additional warning labels on the housing.

The figure below shows the possible places.

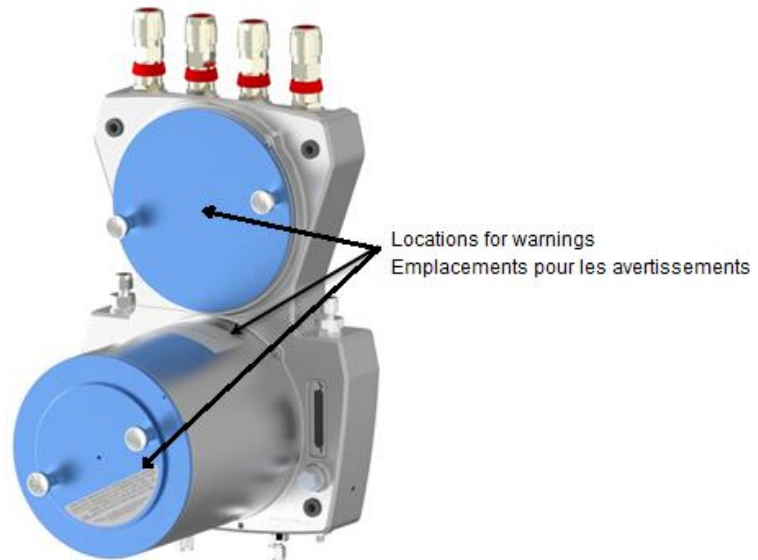

Figure 2.1:
Locations for warnings

Here an example: These notes are also repeated in the documentation at the corresponding place.

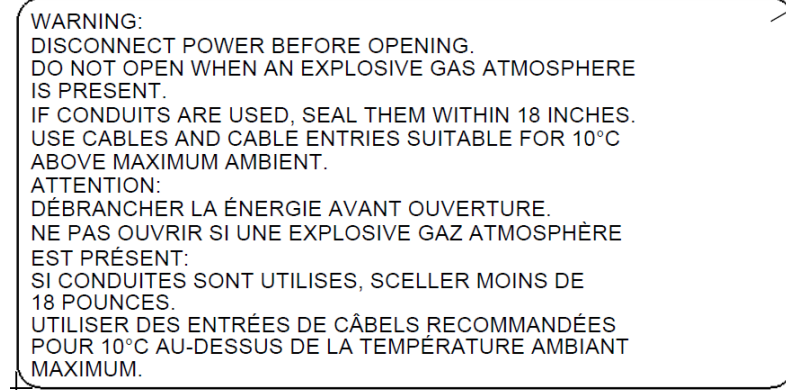

Figure 2.2: Example for warning label in English and French

2.5 Safety information about: Application / gases / ambient conditions

The measurement device requires various gases with different risk potential for operation and measurement.



Gases may form an explosive mixture with air, may be toxic, harmful, or dangerous to the environment.

Un mélange de gaz et d'air peut se former. Ce mélange pourrait être explosif, toxique, et nocif et dangereux pour l'environnement.



It is not allowed to connect gasses that are flammable or explosive under exclusion of oxygen (i.e. acetylene (C₂H₂)).

Il n'est pas autorisé de connecter des gaz inflammables ou explosifs à l'exception de l'oxygène (par exemple, l'acétylène (C₂H₂)).

It is not allowed to connect gas containing more than 3.0 percent of oxygen (volume-based).

Il n'est pas autorisé de connecter un gaz contenant plus de 3 % d'oxygène (basé sur le volume).



Maximum inlet pressure may not exceed 0.5MPa(g) (5 bar(g)). The operator must ensure this! La pression interne ne doit pas dépasser 0.5MPa(g) (5 bars(g)). L'exploitant doit veiller à ce que ce soit respecté!

Only natural gas and gas that is like natural gas (all components are gaseous) may be used. Seuls les gaz naturels et les gaz s'apparentant au gaz naturel (tous les éléments gazeux) peuvent être utilisés.

For other gas types, please contact Elster GmbH before use. Pour de l'information sur d'autres gaz, s'il vous plaît communiquez avec Elster GmbH avant l'utilisation.

For gas specifications, please see chapter 10.

Pour des spécifications sur les gaz, voir le chapitre 10

Drain all exhaust gases from the GasLab Q2, using vent lines according to chapter 5.3.5.

The main breathing element (or just breather) must vent to the ambient atmosphere. Gas will only escape from the breathing element if there is a fault. Inform yourself on appropriate measures for the disposal of effluent gas. This can be achieved by a suitable exhaust / vent tube to a safe area or appropriate ventilation of the location.



The breathing element outlet does not have to be connected, since during normal operation, no gas escapes. If, however, a line is connected to a building, in order to reach a safe area, this ventilation line must be protected from dirt and rain and ventilated atmospherically.

Il n'est pas obligatoire de connecter la soupape de sortie, car en situation normale, aucun gaz ne s'en échappe. Mais si elle est connectée, par exemple pour ventiler vers une zone sûre quand l'appareil est installé à l'intérieur d'un bâtiment, cette sortie doit être protégée contre la pluie et la poussière et ventilé à pression ambiante.

The following specifications apply to vent tubing:

- The allowable pressure drop should be less than 20mbar (2kPa) at a flow of 7.5l/min. This corresponds to a straight smooth tube with minimum inside diameter of 8 mm and length of 40 m. Fittings or curves will reduce the allowable length. Other diameters and lengths, which may increase the pressure drop, are only possible after prior consultation with the Elster GmbH.
- The breathing element venting line connected to the internal thread of the breathing element must remain separated from other vent lines. (In case of any doubt, please contact the Elster GmbH)



DO NOT CONNECT THE BREATHING ELEMENT VENT LINE TO ANY OTHER EXISTING VENT LINE!

NE CONNECTEZ PAS LE RENIFLARD AUX AUTRES SORTIES!

Loosening or untightening of the breathing element by unauthorized persons is prohibited!

Le relâchement ou le dévissage du reniflard' par des personnes non autorisées est interdit!



When working on the gas lines, always ensure adequate ventilation and protect yourself from gases containing aggressive or toxic components.

Lorsque vous travaillez sur les conduites de gaz, assurez-vous qu'il y a toujours une ventilation adéquate et que vous êtes protégé contre les gaz agressifs ou les composants toxiques.



Environmental specifications (see chapter 10.1) must be adhered to. Otherwise, an additional climate control cabinet must be used.

Les conditions environnementales (voir chapitre 10.1) doivent être respectées. Sinon, une armoire climatisée' supplémentaire doit être utilisée.

Only use the device in a potentially corrosive area following consultation with and approval by the Elster GmbH.

N'utilisez l'appareil dans une zone potentiellement corrosive qu'après avoir reçu l'approbation d'Elster GmbH.

Depending on the location of use and ambient conditions, the device may get hot or cold surfaces. This may occur, for example, as a result of self-heating at 55 °C ambient temperature.



Direct contact with hot or cold surfaces can cause burns and frostbites. In case of doubt, the device should be operated via the remote operation panel.

Le contact direct avec des surfaces chaudes ou froides peut causer des brûlures ou des engelures. En cas de doute, on devrait faire fonctionner l'équipement en utilisant le panneau de commande à distance.

2.6 Electrical safety information



The installation must conform to the local standards applying for electrical and explosion safety. (e.g. DIN, EN, VDE, UL etc.)

L'installation doit être conforme aux normes locales concernant la sécurité électrique et les explosions. (Par exemple DIN, EN, VDE, UL, etc.)

As for the installation, (de)commissioning and maintenance in general, reference is made to the corresponding technical regulations. All national, local or corporate standards and regulations that are usable to the location of the Q2 must always be taken into account and applied.



The electrical connections of Q2 must be carried out according to the connection plan (see chapter 5.4.3).

L'appareil doit être branché conformément aux instructions de la section 5.4.3.

The power supply for the device must be protected externally by a fuse or an automatic circuit breaker.

L'alimentation électrique de l'appareil doit être protégée extérieurement par un fusible ou par un disjoncteur.

Overvoltage and current protection for the wiring must also be ensured the power supply.

La protection contre la surtension et les surintensités du câblage doivent également être garanties par l'alimentation.

The electrical connection of the Q2 may only be carried out via the cable connections in the connection box!

Le raccordement électrique du Q2 ne peut être fait par les presse-étoupe dans le boîtier de connexion!

Standards and guidelines on the following topics must in particular be taken into account:

- Electrical apparatus / devices for explosive gas atmospheres areas
- Operation of electrical installations
- Inspection and maintenance of electrical installations in hazardous areas
- Installation of power installations with nominal voltages up to 1000V - tests - initial tests
- Ordinance on Industrial Safety



Q2 has no own off switch. The unit shall be powered via a disconnecting device by means of a switch or circuit breaker and via a current limiting device by means of a fuse or (the same) circuit breaker, in the end use application, complying to ISO/IEC60079-14 and ISO/IEC61010-1. (Operating voltage min. 48V DC)

Le Q2 n'a pas de commutateur marche-arrêt. Dans l'application finale, l'appareil doit être alimenté électriquement par un dispositif de déconnexion proposant un interrupteur ou un disjoncteur et un dispositif limitant le courant proposant un fusible ou un disjoncteur (identique), conformément aux normes ISO/IEC60079-14 et ISO/IEC61010-1. (Tension minimale de 48 V DC)

This disconnecting device (not part of the delivery) must be located in the vicinity of the Q2 according to the explosive and electrical safety regulations. This should consider isolation of all power supply conductors to the hazardous area and comply with the requirements as mentioned in the standard for where it is located.

An example of a device according to the ISO/IEC61010-1 is a circuit breaker, which triggers within 120 seconds at a current of $200/U$. At exactly 24V DC, this current is 8.3 A. A suitable value could be a C4A circuit breaker.



The electrical entry must be installed on site and, if necessary, also replaced there to comply with explosion protection regulations.

This should only be done by authorized personnel who comply with the relevant regulations.

As a result, the Elster GmbH is only be responsible for this work if it was performed by or on behalf of the Elster GmbH.

The housing and mounting design must be included in the local grounding or in the potential equalization. The device must be grounded by the ground screw at the bottom of the housing.



The housing must be earthed. To accomplish this, an earth connection is provided at the bottom of the housing.

The boîtier de l'appareil doit être mis à la terre. Pour cela, une connexion à la terre est fournie sous le boîtier.



Operation of the device without potential equalization or wilful interruption of this connection is prohibited.

L'utilisation de l'appareil sans compensation de potentiel ou de mise à la terre ou l'interruption délibérée de cette connexion est interdite.

Opening the device under voltage or working on its internal energized electrical equipment is generally prohibited, especially in explosive areas. Louverture de l'appareil ou le travail sous tension est généralement interdit. Cela est particulièrement vrai dans les zones dangereuses.

2.7 Risk of explosion / explosive range / protection of explosions



It is forbidden to operate devices with damage, modified housing or inappropriate connections as the protection against explosions is no longer provided.

Il est interdit de faire fonctionner des dispositifs endommagés, dont le boîtier est modifié ou dont les connexions sont inappropriées, car la protection contre l'explosion n'est plus disponible.



DO NOT OPEN GASLAB Q2 IN AN EXPLOSIVE ATMOSPHERE

NE PAS OUVRIR LE GASLAB Q2 DANS UN ENVIRONNEMENT EXPLOSIF

DISCONNECT POWER BEFORE OPENING

DÉCONNECTEZ LA PUISSANCE AVANT L'OUVERTURE

The connection and installation must be carried out according to the listed electrical wiring diagrams, connection diagrams and tubing diagrams. Make sure that all the necessary safety measures have been applied before, during and after working on the Q2 or before turning it on.

**Do not open the lower compartment of the housing
without the permission of the Elster GmbH!**

**N'ouvrez pas la partie inférieure du boîtier sans l'approbation d'Elster
GmbH!**



Please also observe the other sections of chapter 2 and see safety label on the Q2 at all times ⇒ See chapter 10.2

Respectez également en tout temps les autres sections du chapitre 2 ainsi que tous les renseignements de sécurité du Q2 ⇒ Voir la section 10.2

Please contact the Elster GmbH if you have any questions.

2.8 Responsibility of the operator

The operator is subject to statutory occupational health and safety obligations. In addition to the safety notes in these Operating Instructions, current regulations of safety, accident prevention and environmental protection must be observed for the Q2 area of application.

In addition, the operator is responsible for ensuring the Q2 is always in a technically safe state.



The operator must ensure that the installation and maintenance work described in this manual is carried out correctly. The operator is responsible for ensuring that the GasLab Q2 remains in a technically perfect and safe state during its operating period.

L'exploitant doit veiller à ce que les travaux d'installation et l'entretien décrits dans ces instructions sont exécutés correctement. L'exploitant est responsable de s'assurer que le Q2 Gaslab, durant sa période d'exploitation, reste toujours en parfait état de sécurité.

3 Measurement concept of GasLab Q2

3.1 Description of main features

The Elster GasLab Q2 is a real-time natural gas analyzer. It determines the heating value, Wobbe index and other parameters in natural gas. The applications of the device range from fiscal energy metering to measurement, control, and regulation.

One major application is control of the gas turbine of power plants to optimize efficiency, pollutant emissions and system load with fluctuating gas qualities. Another application is gas blending for managing the gas specifications in transportation.

The flameless device measures quickly, continuously, and safely the quality of gas. The correlative measuring principle of the GasLab Q2 is based on the determination of infrared absorption and thermal conductivity of the gas to be analyzed.

The GasLab Q2 is designed to operate in many hazardous areas and wide ambient temperature ranges. This feature simplifies installation and allows the analyzer to be placed close to the process to provide a short response time.

In measurement mode, the gas quality calculations are updated every second. To minimize gas transport delays between the sample tap and GasLab Q2, a bypass flow meter is integrated into the housing.

Routine calibration is performed automatically at a time and day programmed by the operator, using a simple binary mixture.

The analyzer has gas connections for sample gas, calibration gas, measurement (sensor) outlet and (optional used) bypass outlet. Electrical connections for power and I/O communications are conveniently accessible in the top housing.

The measured values are communicated via Modbus protocol and analog outputs. Modbus can be used through two serial interfaces and the Ethernet interface.

Additionally, it is possible to connect external signals to monitor contact closures, e.g. low pressure limit of the calibration gas cylinder.

The integrated display and operation panel, with touch functionality, shows the measurement values and measurement conditions of the analyzer.

The analyzer can be operated via the touch panel or by using a web browser connected to the device. Archives such as error lists and log are integrated. Furthermore, signal and message warnings can be generated.

In addition, the computer software enSuite can be used for configuration, data display and management of the records.



The basic specifications and further information ⇒ See chapter 10 and consult the type plates and metering ranges on the device.

3.2 Description of the operating principle

The operating principle is based on the context of the gas quality characteristics. Heating value, density at base conditions (ρ_n), and carbon dioxide content with various physical quantities of these characteristics. Simpler detectable gas parameters are measured instead of the required target gas parameters. These gas parameters are consistent with the target gas parameters in a physical context.

The following parameters were selected for this process:

- infrared (IR) transmission of CH gas
- infrared (IR) transmission of CO₂ gas
- thermal (heat) conductivity of the complete gas
- Pressure and temperature of the gas

To measure these parameters, the measuring unit includes an infrared sensor to measure the absorption of the hydrocarbons and carbon dioxide contained in natural gas. In addition, another sensor detects the thermal conductivity of the natural gas and thus also detects gas components, such as N₂ (nitrogen), which do not absorb infrared light. By dividing the gas flow into two channels, these sensors operate in parallel.

Furthermore, pressure and temperature are measured. The Wobbe index can be calculated from heating value and density at base conditions. The physical background for the successful description of the gas properties by only three suitable measured variables is the typical composition of natural gas.

All three measurements are subjected to a correlative evaluation and as a result of the heating value provide the density at base conditions and the CO₂ content of natural gas. These sizes are required to determine the other properties of the natural gas. The figure shows the operating principle in a schematic overview (without pressure and temperature).

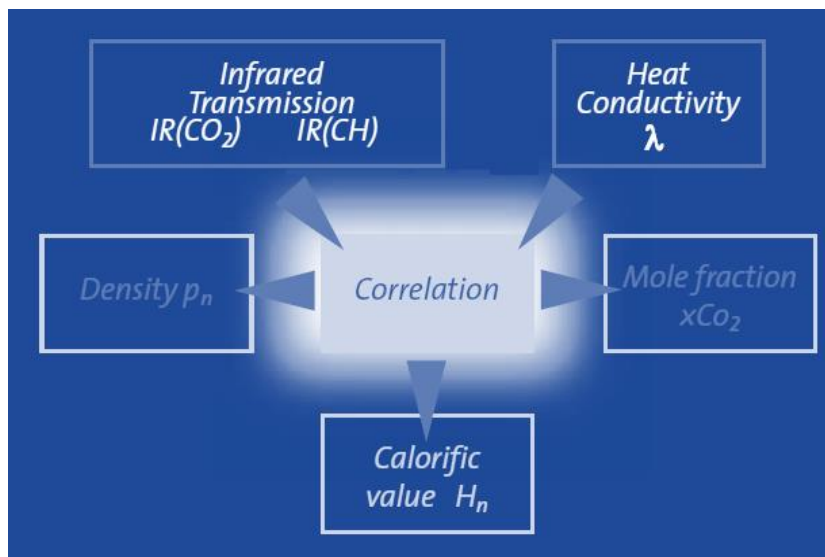

Figure 3.1: Operating principle

The infrared measuring method is based on the fact that gas molecules oscillate in the irradiation of natural gas with white light; this light is weakened at certain wavelengths in the infrared spectral range.

Each IR-active oscillating connection in the molecules makes a contribution to the absorption of light. The different connections cause different absorptions in specific spectral ranges to the absorption spectrum. The kind of absorption and its spectral distribution provides a view of the composition of the gas. See figure 3.2.

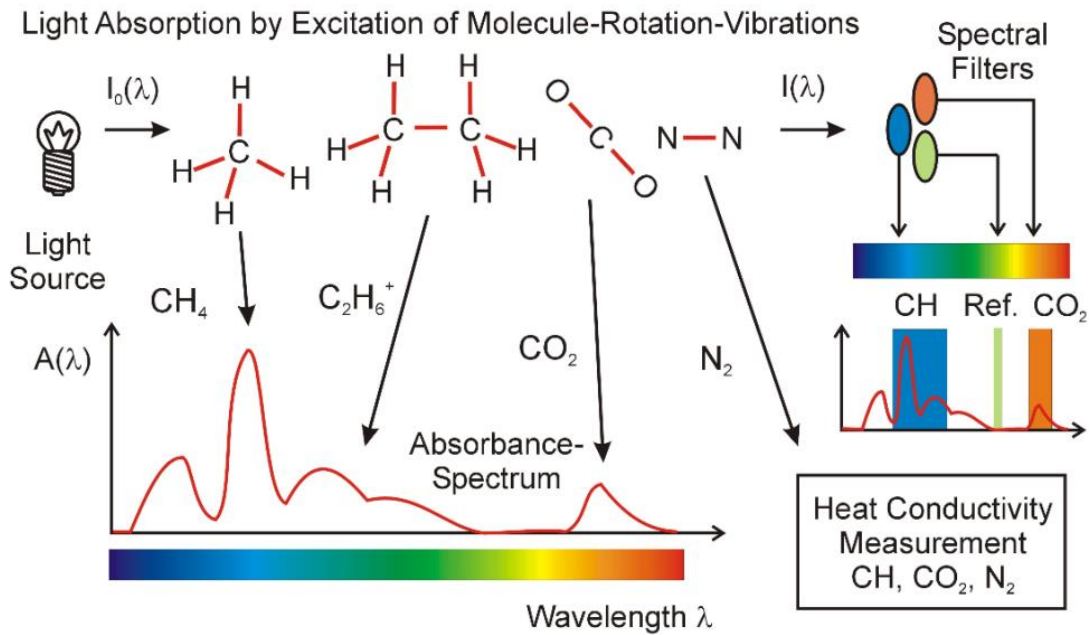

Figure 3.2: Infrared measurement principle

All significant hydrocarbon components in typical natural gas can be detected by IR absorption. The contribution of the hydrocarbon content can be determined for gas specifications, such as gas heating value, density or thermal conductivity, by using the IR absorption.

The method additionally uses a thermal conductivity detector (TCD) in parallel. This is a technical microsystem device and sensitive to all gas components. It also captures the nitrogen contribution. The figure below outlines the principle.

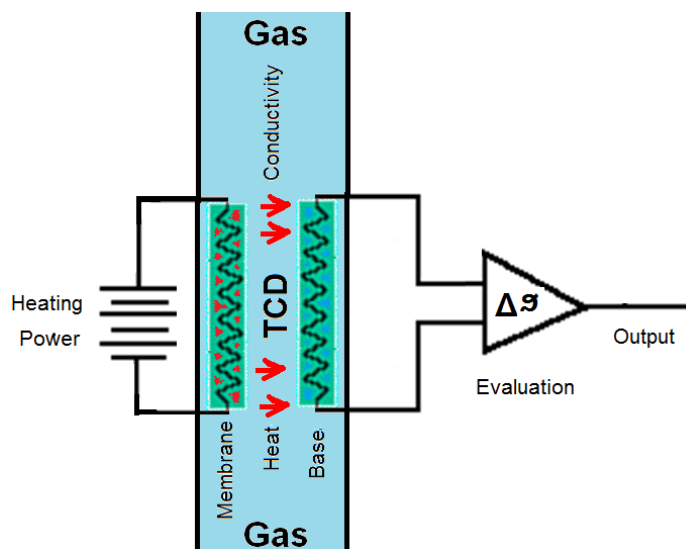

Figure 3.3: TCD measuring method

The thermal conductivity detector includes a heated element (membrane) that heats a second element (base) by using the heat conduction of the gas mixture. The gas mixture to be tested has a lower or higher thermal conductivity, depending on the composition of the gas mixture, so that the sensing element (base) is more or less altered in its temperature. The temperature change therefore also results in a change in the electrical circuit (current voltage resistance). These changes will be evaluated and analysed.

A system of equations can be set up together with the IR measurements, which provides the contribution of the components CO_2 and CH to thermal conductivity and the normalization condition for three-component gas. The searched hydrocarbon fraction x_{CH} is found through the solution.

This means that all relevant gas components are described directly or indirectly through measurands.

3.3 System setup

A typical setup consists of a sample or process gas line from the gas pipeline to the analyzer. The measurement is made rapidly and continuously. A gas stream is fed to the measuring device from the pipeline, measured, and fed into the exhaust tube. If the line pressure is higher than the maximum inlet pressure of the Q2, a pressure reduction must be installed and adjusted before the gas inlet for process gas.

The operational calibration gas is normally located close to the Q2. It is supplied by a 10 l cylinder with a pressure reducer and provides the measuring accuracy. This gas supply lasts for several years of service, and the calibration gas is also available in other cylinder sizes upon request.

The exhaust tubing should be laid separately, details see chapter 5.3.5. In general, all tubing and components should be assembled as fixed gear. The power supply and the communication cables should be connected and installed as usual in an industrial environment. The following diagram shows a typical system setup:

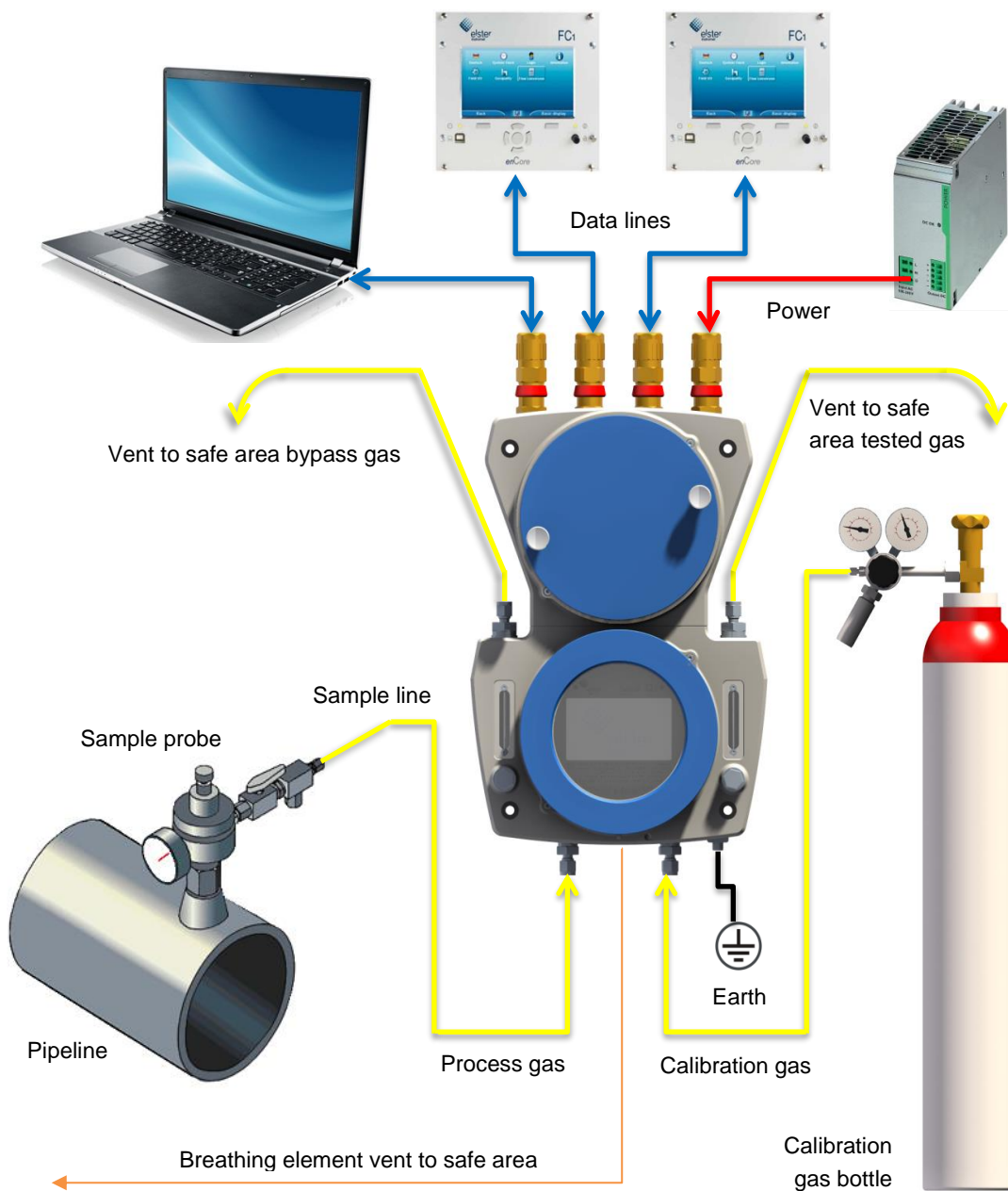

Figure 3.4: General system setup

4 Structure of GasLab Q2

The entire Q2 measurement system is completely integrated in a two-part aluminium housing. Both housing parts are connected mechanically by screws and electrically by a cable bushing.

From a functional perspective, the hardware can be divided into three areas; the instrumentation area (highlighted yellow in the following overview), the connection area (highlighted orange) and the user operating interface (HMI) highlighted in green.

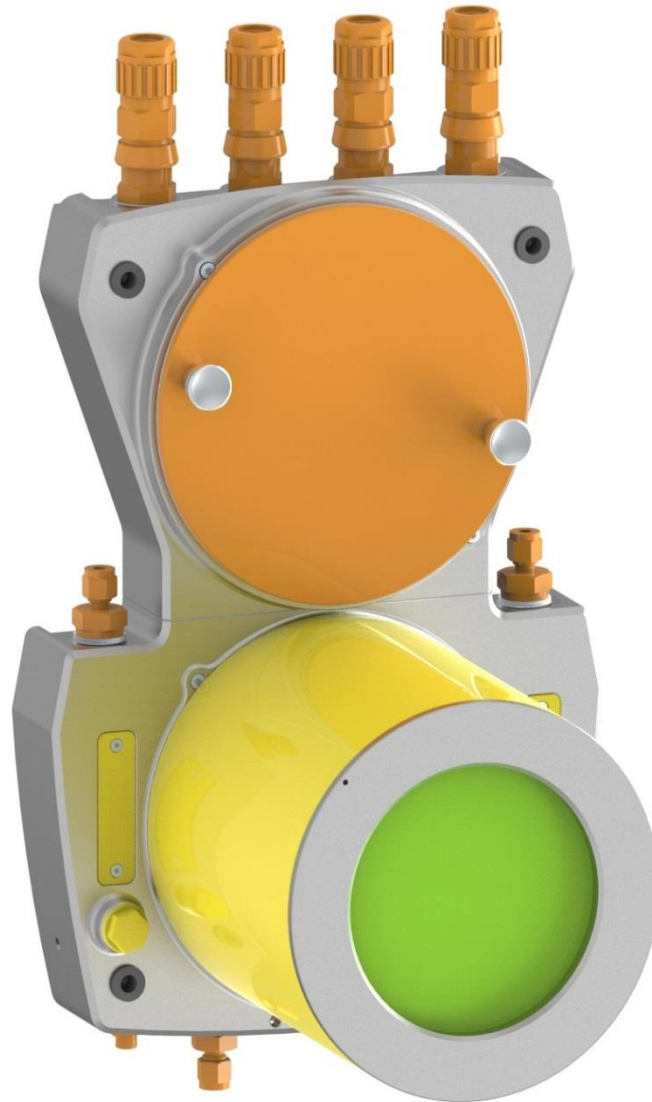

Figure 4.1: Overview of functional areas

The **connection area** forms the interface to external connection ports, such as gas management and electrical access.

The **instrumentation area** includes the fixed structure with functional modules. It provides Elster staff access for production and service issues.

The **human device interface (HMI)** is the operating interface for the user.

These parts are explained in more detail in the following sections.

4.1 Instrumentation area

The instrumentation area contains gas-bearing parts and can be divided into the 2 functional modules GASM (Gas Management) and SENS (Sensor Device).

The GASM part consists of the gas lines in the functional housing part and of the gas channel switching, the double block and bleed valve block. The SENS part is comprised of a block (sensor block) with a pressure regulator and sensors and performs the physical measurement.

All these parts are located inside the device, and are therefore invisible to the operator. Only the interfaces of the functional housing part are visible. As a result, only the functions of these parts are described.

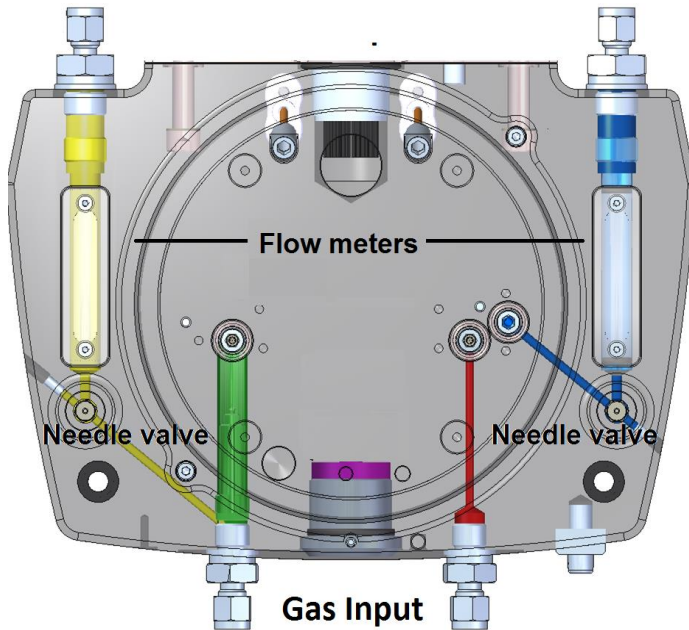

Figure 4.2: Functional housing part

The figure shows the lower housing part of the gas management area. It includes drilled tubes and ducts in the aluminium housing for connecting, distributing and transporting the gas. The gas to be analyzed is supplied via a gas channel to a valve block.

There are two gas inlets and outlets. The gas inlets are used for process gas and operational calibration gas. The gas outlets are for exhaust gas and bypass gas.

The gas inlet for process gas (left side from front view) includes an integrated particle filter. This inlet can be connected to test gases for verification (test gas measurement) purposes.

Optionally, if for example a long process gas line exists, a bypass to speed up the sampling and shorten the reaction time can be opened. The flow of gas in the bypass is indicated by the embedded flowmeter on the left hand and regulated with the left needle valve (highlighted in yellow in figure 4.2).

The analyzed gas stream starts on the gas inlet (highlighted in green) and returns via sensor and valve block (see below) into the lower housing part. The right embedded flowmeter and the right needle valve are used to regulate and indicate the exhaust stream of measured gas (highlighted in blue).

The outflowing gas from the bypass and measuring equipment is removed via the gas outlets in separate exhaust tubes. The flow indicators are used simultaneously for a visual check of the Q2.

A double block and bleed valve block (DBB) with two channels supply the process or the calibration gas to the sensor block. Each gas channel is closed with two solenoid valves.

A gas channel to the vent is built in between the valves. This DBB technology reliably prevents the contamination of the calibration and test gases, even when there are leaks in the valves.

The figure shows the gas passage with open valves during normal operation, which is called analysis.

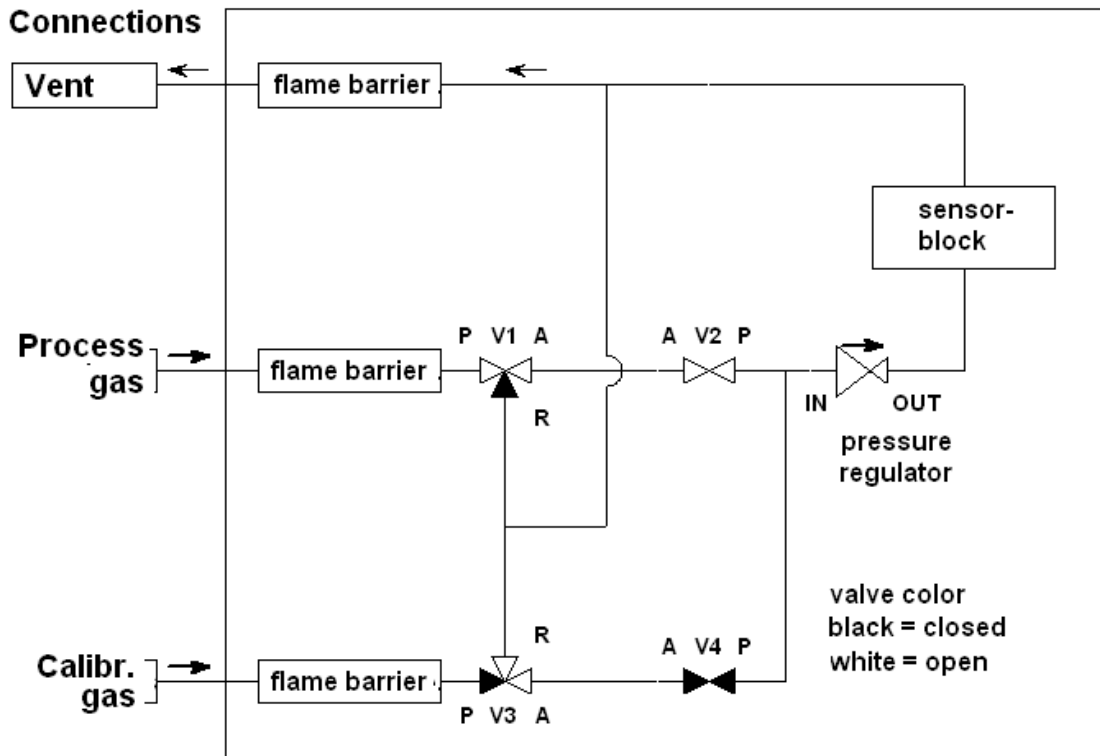

Figure 4.3: Gas passage during analysis function

The sensor block consists of parts with gas channels, attached to electronics and sensors. An integrated pressure regulator reduces the inlet pressure for the measurement.

Then, the gas is supplied to a sensor measuring chamber. The infrared sensor and the thermal conductivity sensor analyze the gas there, and a pressure transmitter measures the pressure of the gas.

In order to get stable results, the block is heated electrically to 70°C. A mounted fan prevents an excessive rise in temperature. A temperature sensor measures the block temperature, called TSB, and passes the information to the control.

The complete control, regulation, and measurement recording is carried out in the sensor electronics. The signals are transmitted digitally. After recording, the measured gas is supplied back into the lower housing part.

The measuring system typically operates at a gauge pressure of about 15 KPa. The typical flow is 30 - 60 l/h. The flow rate can be changed depending on the application (30 l/h standard; 60 l/h fast).

4.2 Connection area

The connection area is divided into the listed parts, which will be described in the following section.

- These are:
- Gas connections (gas inlets / outlets and breather)
 - Electrical connections (electrical entries and connection board)

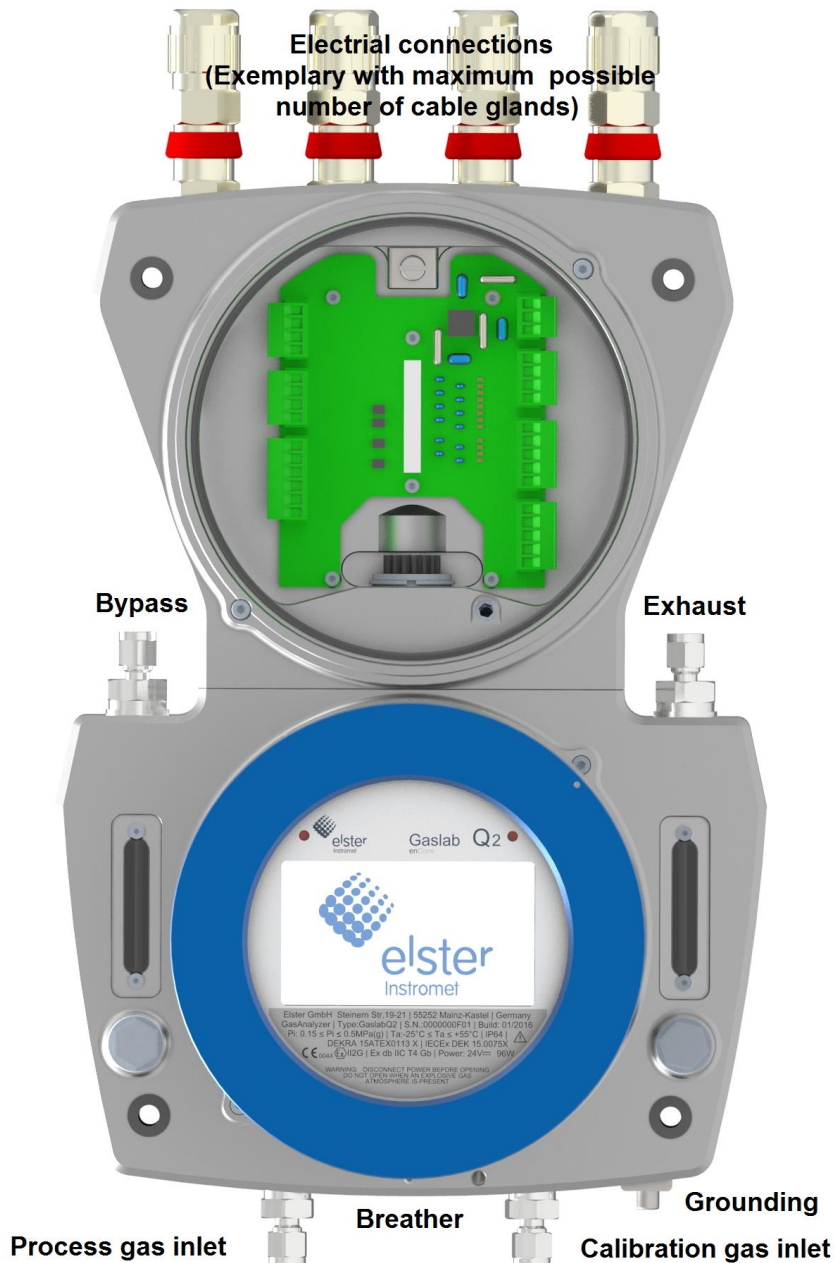

Figure 4.4: Overview of connections

4.2.1 Gas connections and breathing element (breather)

The Q2 is equipped with several gas connections having different functions. There are two gas inlets, and two gas outlets. Two breathing elements are used to allow an atmospheric pressure equalization between the interior and exterior environment of the device. The gas connections are always pipe fittings with 6 mm or ¼ ". They are always equipped by Elster in the standard version Swagelok connectors are used. The required tubing should be permanently attached. An overview of all gas connections and breathing elements is provided below:

Connection	Description	Notes
Left gas inlet	Process gas or verification gas	The inlet pressure must be between 0.15 MPa and 0.5 MPa gauge pressure.
Right gas inlet	Operational or service calibration gas	The inlet pressure must be between 0.2 MPa gauge pressure \pm 0.05 MPa
Left gas outlet	Exhaust gas of integrated bypass	Max. 300 l/h, tube fitting 6 mm or $\frac{1}{4}$ " ; inner tube diameter must be at least 4 mm
Right gas outlet	Exhaust gas of measurement	Default 30 l/h, maximum 60 l/h; tube fitting 6 mm or $\frac{1}{4}$ " ; inner tube diameter must be at least 4 mm
Main breathing element	Vent of instrumentation housing	If an optional vent tube is connected via the $\frac{1}{4}$ " NPT thread, it must have a minimum ID of 8mm. A complete separate tubing is required. !!! Observe the length specifications in section 2.4!!!
Rear breather	Vent of connection box	Vent tubing is not required and not possible

There is an internal particle filter behind the tube fitting for the process gas. The right inlet is only connected to the operational calibration gas cylinder. The breathing element must not be closed or blocked e.g. by water, ice, insects, condensation, dirt or something else, or the pressure compensation will be imperilled.

WARNING / AVERTISSEMENT:



DO NOT CONNECT THE MAIN BREATHING ELEMENT TO OTHER GAS VENTS! NE CONNECTEZ PAS LA SORTIE PRINCIPALE À D'AUTRES ÉVÉNEMENTS À GAZ'!

PROTECT THE BREATHING ELEMENT FROM ANY KIND OF BLOCKAGE ASSUREZ-VOUS QUE LES SORTIES NE SOIENT PAS BLOQUÉES



For more information, ⇒see chapter 5.3.1

4.2.2 Electrical entries and connections

There are four holes, all for electrical purposes (power, communication and I/O services), on top of the device. These electrical entry holes provide a M20x1.5 thread (see figure 4.4). Optionally $\frac{1}{2}$ " NPT thread via adapter is possible, please contact the Elster GmbH for details. These holes have to be equipped with with blind plugs, adapters, or cable feedthroughs. These screw-in parts must have the correct IP class and suitable explosion certifications. They are to be installed and laid according to the specifications of the manufacturer from the screw-in part in order to maintain the stated explosion protection. Two electrical entries and two stopping plugs are used by default as standard for Q2. Other examples of suitable electrical entries would be:

- Certified cable glands with a compression ring.
Which is only permitted in combination with cables:
not being sensitive to cold flow, not allowing air to pass through, and at least three meters long.
(For FM, this applies only when cable and glands are suitable for temperatures up to 80°C)

- Conduit stopping boxes as long as they are sealed

within 1xD from the housing	for ATEX and IEX-Ex
within 18" (45cm)	for FM

- Compound cable glands for IIC area

Only suitable and approved cable entry devices shall be used. Les dispositifs d'entrée de câble utilisés doivent être adaptés et approuvés.

The electrical entry devices shall meet or exceed the IP classification. Les dispositifs d'entrée de câble électriques doivent atteindre ou excéder la classification IP.



For the use in the US NEC, complying cable entry devices shall be used. Pour une utilisation aux USA, les dispositifs d'entrée de câble doivent être conformes au NEC.

For the use in the Canada CEC, complying cable entry devices shall be used. Pour une utilisation au Canada, les dispositifs d'entrée de câble doivent être conformes au CEC.

Elster preferred cable fittings and blind plugs are listed in the following table:

Type of blind plug			Protection	Thread	Part no.
Redapt PA-D brass stopping plug type 'A'			Ex db IIC	M20x1.5	PA-D-1-0-04-00
Type cable fitting	Protection	No. of Cores*	Cable diameter (mm)	Thread	Part no.
Hawke ICG 653/UNIV					ICG 653/UNIV...
flameproof cable gland, castable with two part-sealing compound**, with shield connection	Ex d IIC	6/12	5.5 to 12	M20x1.5	...Os M20 Brass
		6/12	9.5 to 16.0	M20x1.5	...O M20 Brass
		10/15	12.5 to 20.5	M20x1.5	...A M20 Brass



The components mentioned here are necessary accessories for the measurement device, which is included in the recommended version. In addition, even a large number of variations* is possible.**

* Higher number of cores only for ATEX and IECEx; lower number of cores for all other certification.

** In order to maintain the stated explosion protection, the sealing / potting of the cable screw connection must be carried out according to the specifications and notes from the manufacturer of cable fitting!

*** Variation example: Use of conduit with single wires; these must be sealed within 18" (45cm) to meet FM conditions (FM approval is still pending); for ATEX and IECEx it must be within 1xD from the housing just like with a regular gland. Please contact the Elster GmbH, if you want to deviate from the standard.

The upper part of fig. 4.4 shows the electrical entries and the connection box with the connection board for all electrical interfaces (plugs at the perimeter of the board). The plugs are secured by snap-in hooks. The wires to the lower part of housing are located in the middle of the connection board. The corresponding plug must not be removed. For more information ⇨ see chapter 5.4.

Overview of supplied electrical interfaces	
Power supply:	24 V DC fluctuation, including mains fluctuation $\pm 15\%$
Communication ports:	1 x Ethernet (Modbus TCP; HTTP) 2 x RS485 (Modbus serial)
I/O services:	2 x digital input device, self-powered max. 9 V, to be connected to a potential-free contact or NAMUR sensor 4 x Digital output (first one NC, others NO), isolated, max. 120 mA at 28.8V (DC) 4 x analog output (short circuit protection, R max = 390 Ω)

4.3 Human machine interface (HMI)



The actual interface for the human operator consists primarily of an LCD display and a capacitive touch foil located directly behind a glass window. The window can be covered with a screw cap, which offers sand protection in an erosive environment (see Fig. 5.1).

In addition, the HMI area (invisible to the operator) consists of electronic circuits. These communicate with one another via an I/O bus and manage, display, and data record measured data as well as handling of the device. Inputs and outputs are also managed in this area.

Figure 4.5: Interactive display

During normal operation, GasLab Q2 can be operated completely via this interactive display, also known as **operation panel**, since it allows the direct reading of the measurement and target values as well as the control and settings. An onscreen keypad will be displayed if required.

At startup, the GasLab Q2 represents all process-dependent values (e.g. temperature, pressure, etc.) as an error in red writing until measurement conditions are reached. When the measurement conditions are reached, the values are displayed in black, and the measurement will start. Two status LEDs indicate the device state.

To protect against unauthorized use; passwords can be assigned to prevent or restrict access. In addition, operation, and control is possible via Ethernet and associated PC software or browser.



The software is described in more detail in chapters 7 and 8.

5 Transport, storage, installation



This chapter sets out an overview of how the device is handled before, during, and after mounting at the installation location.

Observe the liability notes on page 3 of these Operating Instructions for damage caused by wrong transportation, improper storage, installation, unauthorized modifications or technical changes.

If unauthorized alterations are made to the product or when it is modified, the CE declaration becomes void with immediate effect.

Veuillez respecter les notes de responsabilité à la page 3 de ces instructions en ce qui concerne les dommages de transport, l'installation d'un mauvais entreposage ou l'assemblage et les modifications non autorisées ainsi que les modifications techniques.

Si des modifications non autorisées sont apportées au produit ou qu'il est modifié, la déclaration CE devient nulle avec effet immédiat.

Steps for installation		
1.		Unpack the measurement device and any other components and check them for damage and missing or incorrect parts.
2.		Mount the device in place using suitable mounting tools (not included). ⇒ See chapter 5.2 (Mechanical Installation)
3.		Connect the gas lines as well as the auxiliary exhaust and vent tubes with the Q2 and customize the gas pressures. Open the shut-off valves and check all pipes for leaks. ⇒ See chapter 5.3 (Fluidic Installation)
4.		Install the power supply and connect the communication cable. ⇒ See chapter 5.4 (Electrical Installation)
5.		If you want to use the extended device functionalities, install enSuite on your parameterization device (computer / PC). Installing the PC software enSuite (⇒see chapter 8.2.1)

The installation sequence is described in more detail in the following subsections.

5.1 Transportation / storage

Store Q2 in a clean and dry place. Prevent dirt from entering the interior of the device. Prevent material damage from forming condensation.

Gardez le Q2 dans un endroit propre et sec. Cela empêche la saleté de pénétrer à l'intérieur de l'unité et la condensation de se former.

The following regulations apply for storage:

- environmental specifications (see chapter 10.1) must be adhered to.
- Packaging must only be stored under indoor conditions.
- Mechanical vibrations must be avoided during storage.
- The storage time with battery up to one year; 2 years with subsequent battery substitution.



The Q2 must not be exposed to temperatures below -25°C or above $+55^{\circ}\text{C}$.
Le Gaslab Q2 ne doit pas être exposé à des températures inférieures à -25°C et $+55^{\circ}\text{C}$.

If transported in cold weather, or if subject to extreme variations in temperature, the device must be slowly brought to room temperature before it is commissioned to prevent damage from formation of condensation.



Removal of of transportation protection or dirt protection is not allowed before the device is installed at its final position, and as long as dirt is still able to penetrate.

Le retrait des dispositifs de protection de transport et des dispositif de protection contre la saleté n'est pas autorisé avant l'installation finale de l'appareil, et cela demeure vrai tant et aussi longtemps que la saleté peut pénétrer l'appareil.

5.2 Mechanical installation of GasLab Q2



Only a proper installation will ensure the secure and smooth operation of the device.

5.2.1 Location of use and installation



Note: always follow the explosion regulations when using devices or tools in hazardous areas.

Remarque dans les zones de danger doit règles de protection contre les explosions lorsque vous travaillez avec des outils ou des objets.



If possible, install the Q2 close to the process gas tapping to avoid long lines and to get current measurement values.

You need a width and height of 270x500mm for the installation (in the visual field) and a certain clearance on either side and in front of the Q2 for maintenance.

The measurement device weighs about 16 kg. Make sure that the installation area has sufficient stability.



The place of installation, if it is outdoor, must be protected against direct sunlight and rain e.g. by way of a metal roof. Likewise, a windbreak may be required when the device is installed in a windy environment with temperatures below freezing. A sand protection (display cover) of the device should be used in sandy environments.

L'emplacement d'installation du site, s'il est à l'extérieur,, doit être protégé, entre autre, de l'irradiation solaire directe et de la pluie par un toit en tôle. Un brise-vent peut être nécessaire lorsque l'appareil est installé dans un environnement venteux avec des températures inférieures à zéro. Une protection contre le sable (couverture) pour l'appareil doit être installée lorsque celui-ci se trouve dans un environnement sablonneux.



Make sure that the device cannot be hit by a water jet (e.g. during cleaning the plant). Alternatively, installation in a ventilated cabinet is recommended in extreme environmental conditions. Please contact the Elster GmbH for more information.

Assurez-vous que le dispositif ne peut pas être frappé par un jet d'eau (par exemple, lors du nettoyage de l'usine). Autrement, dans des conditions environnementales extrêmes, l'installation dans une armoire ventilée est recommandée. Veuillez communiquer avec "Elster GmbH pour plus de renseignements.

The Q2 does not require a separate mounting plate, because it contains all of the parts required to perform the measuring task in its flameproof enclosure. Installation can be on a vertical flat surface (wall / or panel). For this purpose, mounting holes with a diameter of 8 mm are provided in the housing.

For fixation, use fasteners of at least the size M6 (M8 recommended) or equivalent for all 4 mounting holes. Suitable counterpart (i.e. nuts or chemical anchors) may be required depending on the material and type of the structure to which the unit is mounted. The material of the structure to which the unit is fixated must be able to withstand a combined vertical load of 1000N on the four mounting points.



The Q2 must be installed so that the breathing element is pointing down and the electrical entries are facing up.

Le Q2 doit être installé de telle sorte que le reniflard' principal et les entrées du câble électrique soient orientées vers le haut.

Select an appropriate mounting height for easy viewing and operation, e.g. from 1.1m to 1.8m above the ground.

Choisissez une hauteur de montage appropriée pour le fonctionnement et la visibilité, Par exemple de 1,10 à 1,80 m au-dessus du sol.

5.2.2 GasLab Q2 dimensions

Please refer to the following drawing for mechanical installation. All measures in mm. The items (1) (2) (3) dependent on connection types and excluding tube / cable.

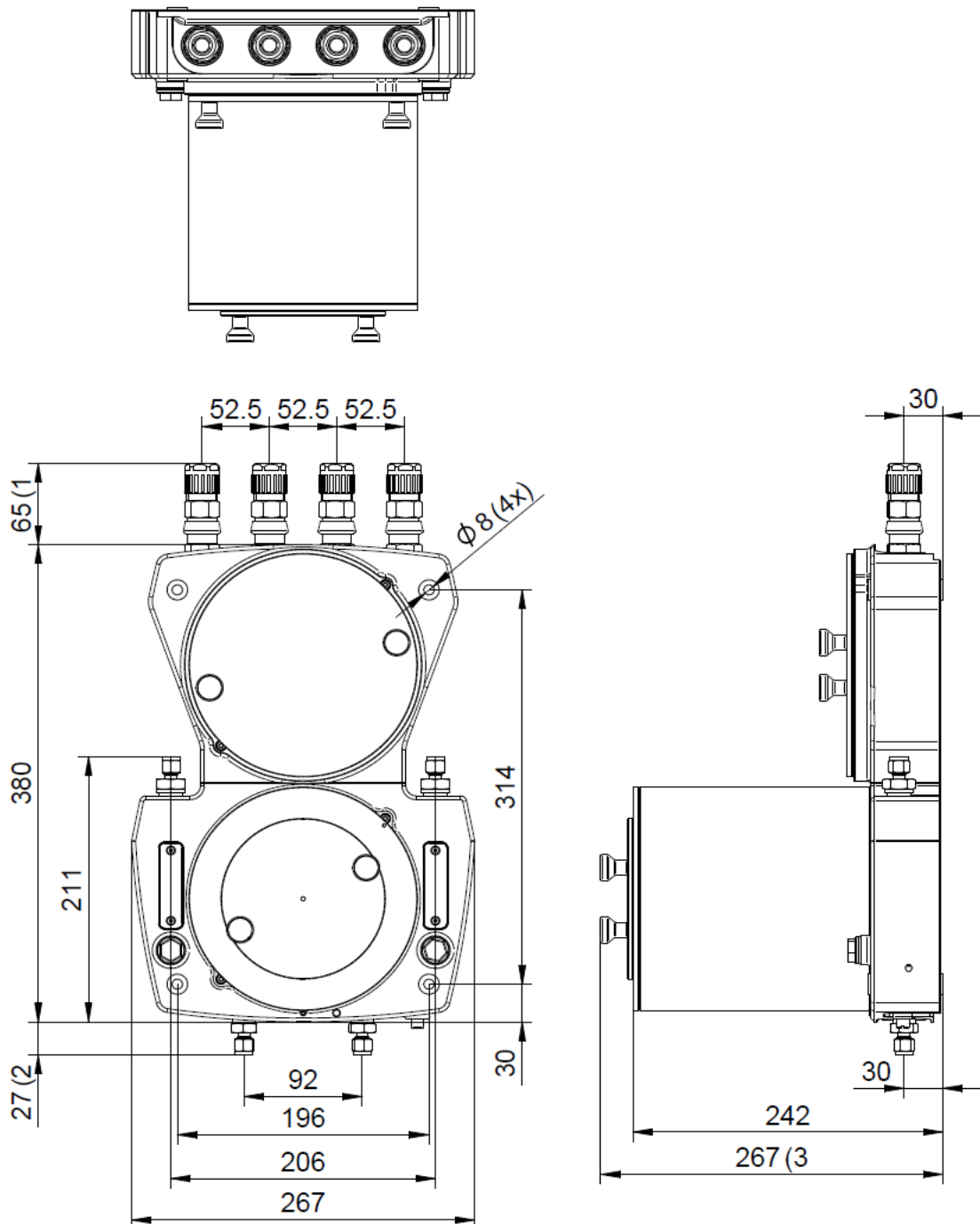

Figure 5.1: Dimensional drawing with optional sand cover

5.2.3 Dismantling

Please observe the following notes before removal of the device to prevent any risk of sparks, release of flammable gas, and explosions (in the hazardous area).



Dismantling is prohibited without switching off beforehand all supplies, such as pressure and electricity (power and communication).

Le démontage est interdit sans avoir préalablement éteint toute alimentation, en pression et en électricité' (l'électricité et la communication).

It must be guaranteed that the power, communications, and gas cannot be accidentally turned back on, so that there is no danger of disassembly. Il faut veiller à ce que la tension d'alimentation, la communication et les gaz ne puissent pas être accidentellement rallumés, de sorte qu'aucun danger ne survienne à la suite du démontage.



If you wish to continue using the device at a later time or if you want to send it back, you must return it to the state in which it was delivered. (transportation protections, dummy plugs, covers, etc.)

5.3 Fluidic installation of GasLab Q2



The specified maximum pressure on the gas inlets of Q2 must not be exceeded to prevent damage to the device and dangerous situations. La pression maximale spécifiée pour les entrées de gaz du Q2 ne doit pas être dépassée, afin de prévenir les dommages à l'appareil et les situations dangereuses.

This must be guaranteed by an external protection, which is not an integral part of the Q2.

Celle-ci doit être assurée sur place par une protection externe, qui ne fait pas partie du Q2.

The required tubes and protection devices have to be provided according to the general guidelines as well as the requirements in these Operating Instructions.

Les dispositifs de tuyauterie et de sécurité obligatoires doivent être utilisés conformément aux règles et règlements applicables de ce manuel.

5.3.1 Gas connections

The Q2 has two gas inlets (connection according to chapter 4.2.1). Both are protected by a flame arrestor.

The Q2 also has two gas outlets (connection according to chapter 4.2.1). One is used to vent measured gases, the other to bypass the measurement, if necessary, for speed optimization purposes.

The outflowing gas is then to be led into the exhaust gas line without any appreciable overpressure (pressure difference to the current ambient pressure) exhaust gas line. Please contact Elster GmbH for application notes.

The gas inlets and outlets are labelled on the device (⇒ See chapter 10.2.3)

- No. Gas connection
- 1 Process gas (PG) inlet
Inlet pressure: 0.15 to 0.5MPa (gauge)
with an internal sintered particle filter
 - 2 Calibration gas in cylinder (CAL)
Operational calibration gas (CH₄ + CO₂)
0.2MPa (g) ±0.05MPa
Maximum inlet pressure: 0.25MPa (gauge)
 - 3 Integrated bypass outlet
Flow rate: up to approx. 300 l/h (if necessary)
 - 4 Exhaust gas outlet
Standard measurement way sensor
Flow rate: typical 30l/h
Flow rate: max. 60l/h
 - 5 Main breathing element with thread: ¼" NPT
for piping, min. ID 8 mm, length according to chapter 2.4.
Completely separate installation is necessary.
 - 6 Rear breathing element
Integrated in rear side of connection box
No piping possible nor required

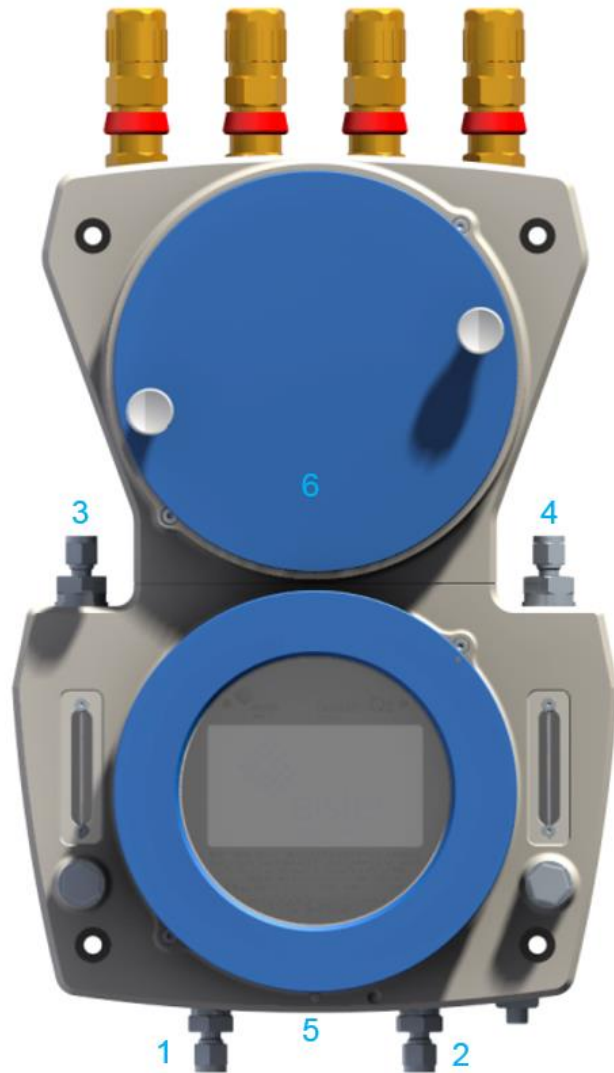

Figure 5.2: Definition of gas connections



⇒ See chapter 4.2.1 and 10.

5.3.2 Connecting gas lines (general)

The recognized rules of technology for dealing with pure gases must be observed during all works as described. Surfaces that come into contact with gas must be free of grease, oil, solvents, and other contaminants.



All gases may not be altered or corrupted during transportation from their source (pipeline / cylinder) to the measurement device.

Install the gas tubes up to the Q2. Carry out according to the piping diagram of the plant operator. Make sure that each line or each gas passage contains the required safety and shut-off devices.



All lines must be kept as short as possible. Use only dense, clean gas lines. Take measures to prevent dirt and/or moisture reaching the device and distorting the measurements or causing damage. Stainless steel fulfills these properties. Fittings and pipe joints with small dead volumes are preferred.



Mixing of tube fittings parts of various brands for the production of gas-related equipment connecting is prohibited.
Le mélange des éléments de fixation de divers fournisseurs de systèmes pour la manufacture d'équipement de production de gaz est interdit!



Before connecting to the Q2, make sure that the inside of the line is clean, e.g. by flushing with gas for approx. 30 sec.

Avant de brancher l'appareil, assurez-vous que le câble 'intérieur est propre, par exemple, par en rinçant avec un gaz pendant environ 30 secondes.

Purge gas must be professionally and safely discharged.

Le gaz purgé doit être évacué de manière professionnelle et en toute sécurité

5.3.3 Preparing the process gas connection

Process gas is retrieved from the process line (pipeline). The sampling device should have temperature compensation and pressure control. It should be located as close as possible to the Q2.



The particle filter inside the process gas inlet of the Q2 serves the protection of the device and is not a substitute for a primary filter system, and it must not be used for these purposes.

Le filtre à particule' à l'intérieur du d'alimentation en gaz du Q2 sert à protéger l'appareil et ne remplace pas pour un système de filtre primaire, il ne doit pas être utilisé à ces fins.

A primary filter system is required in any case, if the gas specifications (see chapter 10) are not met.

Un système de filtre primaire est nécessaire dans tous les cas, si les spécifications du gaz (voir chapitre 10) ne sont pas respectées.



Volume and pressure of the sample line influence the total response time of the system and, thus, the delay between the moment of sampling and the measurement result.

Additional shut-off valves, pressure reducers, filters, gas dryers, etc., may have to be provided so that the sampled process gas meets the required specifications when entering the device.

Connecting steps process gas sample line		
1.	▶	Make sure that there is a shut-off valve* in the process gas sample probe or the pipe system, which you want to connect to the Q2. Make sure that this shut-off valve is closed. A suitable pressure regulator* may be required as well. If a pressure regulator* is present, turn the regulator to its lowest setting.
2.	▶	Connect the process gas sampling with the pipe system. Do not connect the Q2 yet!
3.	▶	Carefully open the shut-off device valve of the pipe so that a permissible flow of gas is generated above the measurement conditions. Then purge for about 30 seconds** to clean the process gas sampling line. Drain the gas at the end of the line using a hose to ensure proper safe exhaust. Check if the pressure and other parameters will fit before doing so.
4.	▶	Then close the line shut-off device and restore the previous settings! The exact pressure will be adapted later, after connecting the Q2
5.		The process gas sample line is now ready to be connected to the Q2. ⇨ See chapter 5.3.6 Prevent the ingress of dirt and moisture if the connection is carried out immediately.

*not part of device and delivery; make sure to use a type that meet the specifications and standards

** If long lines are used extend this time

5.3.4 Connecting or replacing gas cylinders

A regular automatic calibration / adjustment with an operational calibration gas is required for the proper operation of the Q2. A gas cylinder with a CH₄+CO₂ mixture is required. The cylinder should be replaced as soon as the outlet pressure cannot be kept stable any longer.

Depending on the regulator, this will usually occur around 0.5MPa. The pressure in particular should be monitored using a pressure gauge or contact pressure gauge, for example. For more options and details of calibration gas mixture, please contact the Elster GmbH.

Some situations make it necessary to connect an additional gas cylinders to the device, e.g. for verification purposes. This work must be carried out according to the steps described herein.











Always follow the steps of the cylinder change according to local regulations and the working steps in the Operating Instructions.
Suivez toujours les étapes du changement de cylindre établies selon les normes locales en respectant les étapes de travail inscrites dans les instructions de ce manuel.

Failure to comply may result in substantial damage to the device or the station.
Le non-respect de ces étapes peut entraîner des dommages importants à l'appareil ou au système!



A suitable pressure reduction is required to connect a gas cylinder to the calibration gas inlet of the Q2. Elster GmbH offers prefabricated panels with high pressure reductions for this purpose

Steps to connect the gas cylinder		
1.	▶	Secure the cylinder against tilting over.
2.	▶	Unscrew the protective cap from the cylinder
3.	▶	 Make sure that the main valve on the cylinder is closed.  If this is the case, remove the screw cap (plug) from the valve connection.
4.		A cylinder pressure reduction with overpressure protection must be provided.
5.	▶	 Make sure that the regulator* is set to the lowest setting and the shut-off valve (if present) of the pressure regulator to be connected is closed.
6.	▶	Close the cylinder connection of the high-pressure reducer or cylinder pressure regulator* to the valve connection of the gas cylinder.  Do not put any oil or grease on the threads.
7.	▶	Flushing of the pressure reduction (see below) is recommended at this point for accuracy reasons.
8.	▶	After rinsing, the outlet of the pressure reducer is to be connected via a high-pressure hose or a fixed pipe to the corresponding intake of Q2. If this is not yet possible, cap the gas line with a dummy plug to continue with step 9 at a later stage.
9.	▶	Open the main valve of the gas cylinder. Adapt the output pressure of the pressure regulator* to the required pressure for the working pressure approx. 0.2MPa (g)  Maximum pressure of 0.25MPa (g)
10.	▶	 Check for carefully for tightness. 

Working steps for manual flushing of a pressure regulator*		
1.	▶	 Make sure that the following requirements are met: <ol style="list-style-type: none"> 1. Steps 1 to 6 of the gas cylinder connection procedure (see above). 2. A gas flow can take place in the parts to be flushed. To be able to flush (drain) the gas line and its components, it should be disconnected from the GasLab Q2 (gas cylinder closed!). Make sure the gas can be drained in a professional and safe way.
2.	▶	Slowly open the main valve of the gas cylinder.
3.	▶	Establish the gas flow and observe it with the flow indicator. Do not exceed the maximum permissible pressures.
4.	▶	Now close the main valve of the gas cylinder.
5.	▶	If the output pressure of the pressure regulator* has almost fallen to zero, due to the discharge of gas, open the gas cylinder briefly and close it again.
6.	▶	Repeat step 5 to ensure that there is no more air or other contamination left in the dead volume of the regulator. After a total of 5 cycles (filling / draining), everything will be flushed out.
7.	▶	After the flushing process, continue immediately with step 8 of the gas cylinder connection procedure (see above) to prevent any contamination from entering the regulator again.

(*not part of Q2, make sure to use a type that meets the specifications and standards if not from Elster)

Working steps for removing the gas cylinder		
1.	▶	Close the gas cylinder main valve.
2.	▶	Depressurize the connected gas line
3.	▶	Remove connections from the gas cylinder
4.	▶	Protect the connection thread of the cylinder valve with the associated screw cap.
5.	▶	Put the protection cap on the gas cylinder.
6.	▶	Loosen the protection against falling down and remove the gas cylinder
7.	▶	Protect the connection thread of the unused cylinder connection with a suitable protective cap if a new gas cylinder is not installed immediately.

5.3.5 Connecting the exhaust tubing

In regular measuring mode, the entire gas flows through the device and is discharged via the exhaust tubing to secure ventilation areas outside buildings.

The gases from measurement and (if used) bypass must be drained **without back pressure** through this exhaust tubing. It is connected through a 6 mm Swagelok connector and must have an inner diameter of at least 4 mm.

Never decrease diameters of exhaust lines!

The exhaust tube must be laid separately for at least 1 m (recommended 3 m) before it is connected to larger exhaust pipes of other equipment. For long lines or manifolds, the required inner minimum diameter is 12mm (1/2"). If the bypass is strongly penetrated, a separate exhaust pipe should preferably be installed for this exhaust tube in order to avoid back pressure.



If the bypass is not used, the protective cap on the bypass drain must be replaced by a blind plug for proper sealing!

Si la dérivation n'est pas faite, le bouchon de protection sur le dispositif de dérivation doit être remplacé par un bouchon factice pour que tout soit bien scellé.

The associated needle valve on the left side of the device may only be opened when bypassing.

La soupape à pointe gauche associée peut être ouverte même lors de l'emploi d'un dispositif de dérivation'.



The gas drain connections of the unit must ventilate atmospherically and be protected against dirt or liquids.

Les évents à gaz de l'appareil doivent ventiler à pression ambiante et être protégés contre la poussière et les liquides.

These venting lines shall be routed to a safe area away from the Gaslab Q2 because of the permanent flow of flammable gas.

Ces conduites de ventilation doivent être dirigées loin de l'appareil Gaslab Q2 en raison du flux constant de gaz inflammable.

Steps to connect the exhaust tube	
1.	Connect the exhaust to the respective outputs.
2.	Connect the line immediately after you took the dirt protection off the connection of Q2.
3.	Since a leak test cannot take place with the device shut off, the exhaust tube has to be tested while flushing, with a gas detector for tightness. This test should be done first when the device is installed and running.



The breathing element line (if connected) is not part of the exhaust system and may never be connected to other lines.

Le tuyau du reniflard (si connecté) ne fait pas partie du système d'échappement et ne doit jamais être relié à d'autres tuyaux d'échappement!

5.3.6 Connect Q2 to the processgasline and completethe fluidic installation

Working steps to connect measurement device with the process gas line		
1.	▶	Ensure that all work required according to the preceding sections in chapter 5 was carried out. Particularly the flushing of the gas lines
2.	▶	Make sure that the process gas line is connected to the sample probe according to chapter 5.3.3. Check in particular that the shut-off valve in the process gas line is closed. (If a pressure regulator is installed, it has to turn to its lowest setting)
3.	▶	Make sure that subsequently there is a process gas pressure present that is suitable for the inlet pressure range of the Q2 from 0.15 to 0.5 MPa (gauge pressure).
4.	▶	Remove the protection (blanking plugs / sealing screws) from the entry point of the device and connect the gas line for process gas (PG) - according to figure 10.3 on the input.
5.	▶	Then slowly increase the pressure to the desired setting by carefully opening all valves and pressure regulators in the process gas line.



The needle valve on the right side of the device is only used for regulation; it is not a cut-off valve and must never be completely closed.

La soupape à pointe sur le côté droit de l'appareil n'est utilisée que pour la régulation, il ne s'agit pas d'une vanne d'arrêt et elle ne doit jamais être complètement fermée!



After completion of the entire installation, when all gas lines are connected and pressurized, a leak test must be carried out.

Après toute l'installation terminée, lorsque tous les tuyaux de gaz sont connectés et mis sous pression, un test de fuite doit être effectué.



Since the test cannot take place at all parts when the device is switched off, the leak test for these parts must be carried out or made first while the device is running.

Comme le test ne peut être fait lorsque l'appareil est éteint, le test de fuite pour ces composants doit être fait avant que l'appareil soit mis en marche.

5.3.7 Leak test of the installation



Leaks in the gas supply lines increase the risk of explosion and may lead to inadequate measurement results.

Les fuites dans les conduites de gaz augmentent le risque d'explosion et peuvent mener à des mesures insuffisantes!

Steps for leak test:		
1.	▶	Close the valves by interrupting the power supply to the Q2. (if it is already in use)
2.	▶	Apply pressured gases to all inlet gas lines of the measuring device so that a gas volume is present in the lines.
3.	▶	Check the whole installation for leaks with a gas detector.
4.		If a leak is detected it has to be fixed (sealed) immediately. Stop the gas supply! Seal the leak! Repeat the leak test!
5.		Do not carry out any other acts or work before everything is tight!

5.4 Electrical installation



There must be an effective and functioning lightning protection system in place to protect personnel and equipment at the location of use.

Pour la protection du personnel et de l'équipement, un système de protection efficace contre la foudre doit être mis en place.

The device has no own off switch.

Le dispositif n'a pas d'interrupteur marche-arrêt dédié.

An external switch off equipment (not part of delivery) is required. It must be installed by the station operator in the vicinity of the device. (see chapter 2.5 and 5.4.1)

Un dispositif externe d'arrêt (non inclus) doit être installé près de l'équipement par l'exploitant de l'installation. (Voir la section 2.5 et 5.4.1)

Always observe general safety rules, particularly in potentially hazardous atmospheres.

Respectez toujours les règles générales de sécurité, en particulier, dans un environnement dangereux.

Always use a personal gas monitor when working on the device.

Utilisez toujours un détecteur de gaz personnel lorsque vous travaillez sur l'appareil.

Always turn off all power (supply and sensors) before electrical connections are made or loosened.

Assurez-vous qu'avant toute modification du câblage (alimentation ou capteurs), l'appareil est hors tension.



The device must be connected to the potential equalization at the location of use.

L'appareil doit être branché et mis à la terre sur le site d'utilisation.

The power supply (24V DC) must be provided according to chapter 2.3.

L'alimentation électrique (24V DC) doit être effectuée conformément aux dispositions du chapitre 2.3.

The electrical connection plan of the device specified hereinafter must be strictly adhered to.

Respectez strictement le plan de connexion électrique de l'appareil spécifié ci-après.

If you use a PELV system the wiring is different. Please contact the Elster GmbH in this case.

Si vous utilisez un système PELV, le câblage est différent. Veuillez communiquer avec Elster GmbH.



The device is protected against reverse polarity.

The device does not work if the connections are interchanged.

5.4.1 Power supply / electric protection / grounding

The 24 V (DC) power supply must be re-inforced isolated from mains.

L'alimentation 24 V (DC) doit être isolée de manière renforcée des autres réseaux.



The overvoltage/current protection and electrical line protection must be ensured by the power supply.

La surtension/surintensité et la protection de la ligne électrique doit être garantie par l'alimentation.

Q2 does not have any protective equipment accessible to the user.

Le Q2 ne possède pas de dispositif de protection des équipements accessible aux utilisateurs.



Q2 contains internal thermal and electrical fuses that are neither reset nor replaceable. Please contact the Elster GmbH if these protective devices have tripped. See also chapter 7.4.5.

Check the incoming voltage, at the location of use, for accuracy and usability according to the following data:

Power supply (according to chapter 2.3)	Voltage range: 24 V DC fluctuation, including mains fluctuation $\pm 15\%$
	External circuit breaker that triggers within 120 seconds* is installed
	Up to 96w power are available.

* Note: the breaking current equals 200 supply voltages. Breaking depends on the ambient temperature. This must be taken in to account when the fuse is installed at a temperature significantly different from the room temperature.



The housing must be earthed. To accomplish this, an earth connection is provided at the bottom of the housing.
The boîtier de l'appareil doit être mis à la terre. Pour cela, une connexion à la terre est fournie sous le boîtier.

The housing must be earthed. Use the provided grounding screw on the bottom of the Q2 (see figure 5.4) next to the calibration gas input to connect the device to the local ground. This is the main PE terminal.

The permissible conductor cross-section for grounding is at least 6 mm² (maximum 10 mm²) of the copper cable. The earth connection has been already set up and must be used in the specified manner without modification. The tightening torque of the connection must not exceed 3.5Nm.

The shields of the supply and communication cables are connected according to local conditions and regulations. Function grounding points (FE) are located in the connection box. See figure 5.3. Make sure always to connect to the same grounding potential.

If the Q2 is mounted on a metal frame, this frame must be connected to the local ground too.

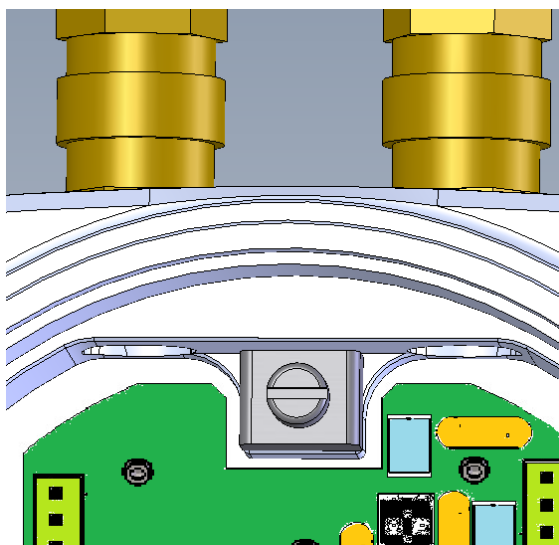

Figure 5.3: Connection box with functional grounding



Figure 5.4: Earthing/grounding of housing for protection

5.4.2 Cables and electrical entries (power supply and communication)

The cables or wires are passed through cable fittings at the top of the device into the connection box. All electrical interfaces are located here and have a galvanic isolation. Cables must be shielded. When selecting the electrical entries, you must comply with the particular manufacturer's instructions. Choose an appropriate type depending on the location and request for that device.



The temperature on the connection box may rise to a temperature 10°C (10K) above the ambient temperature. Make sure cable entries and cables are suitable for this increase under ambient conditions on site.
La température du boîtier de connexion peut monter jusqu'à 10°C (10K) au-dessus de la température ambiante. Les entrées de câbles et les câbles doivent être adaptés à cette augmentation de la température locale.



Cables, wires, cable glands, adapters and blinds are standard products (not from the Elster GmbH) which are necessary for the operation of the Q2. It is recommended to disconnect the data cables from the power supply cable.
Observe also the information in chapter 4.2.2

The cables are connected to the terminal board in the connection box via the plugs on the edge of the board. The local / national installation standards (e.g. EN 60079-14 for Europe) must be considered. It should be noted that the protection class IP 64 must be maintained. The degree of protection of the parts used (electrical entries, stopping plugs and adapters) must be the same as the device itself or better (higher). Most systems require only 2 cable glands, one for the data transmission cable and one for the voltage supply (24 V DC). Remaining positions may be used for additional signal cables.

Unused openings must be fitted with suitable certified blanking plugs.
Les ouvertures non utilisées doivent être munies d'obturateurs certifiés.

Figure 5.5 shows the position and number of the electrical entries. Use only shielded wiring.

The relevant installation guidelines must be followed, so wires must be at least flame-retardant class 1. The connection terminals are suitable for conductor cross sections from 0.25 mm² up to 2.5 mm². For the power consider supplying a max. rated operating current of 4 A (also consider the voltage drop). In case of a short circuit the power supply must be able to break the external circuit breaker or the internal 4A fuse. Signal cables require conductor cross sections larger than 0.25mm².

As a rule, the connection cables can be routed to 2 separate locations without an additional ex outlet. For the connection between Q2 and other equipment, various control and signal cables are suitable. The selection is based on the requirements at the place of use. The Elster GmbH generally recommends a signal cable with a line-to-line capacity < 120pF/m and an inductance < 0.7 µH/m.



Figure 5.5: Position of electrical entries

The number of cables varies, depending on the application. Each pair of cable should be twisted together and shielded together.

The maximum cable length depends on the type of signals and must not be exceeded.

A type of cable according to Category 5 (Cat 5) is recommended for data communication connections via Ethernet. See also the following chapter.

5.4.3 Electrical connection plan and electrical interfaces (outputs and inputs)

The connections and interfaces described below are located in the Q2 connection box. They are supplemented and explained in Fig. 5.6 as well as in the following section.

Connector	Interface
TB1	Power supply (see also chapter 2.3)
TB2	Future use
TB3	Ethernet port 10/100 Mbit/s Galvanic isolation Distance up to 100 m
TB4	RS485 port 1 and port 2 Galvanic isolation Distance up to 500 m
TB5	Digital input 1 and 2 Dev. powered max. 9 V Galvanic isolation
TB6	4 Digital outputs Galvanic isolation Common ground (Semiconductor circuit operates as a potential-free contact) max.120 mA at 28,8V (DC))
TB7	4 Analog outputs 0/4...20 mA Galvanic isolation Common ground Short circuit protection R max = 390 Ω



Never remove the plug connection in the middle of the connection board!
Ne retirez jamais le bouchon au milieu de la planche à bornes!



Check for tightness of connectors! Screws of unused terminals must be tightened!
Vérifier l'étanchéité des connecteurs! Les vis de bornes inutilisées doivent être serrées!

Electrical connections for the Q2 can be found in the following overview:

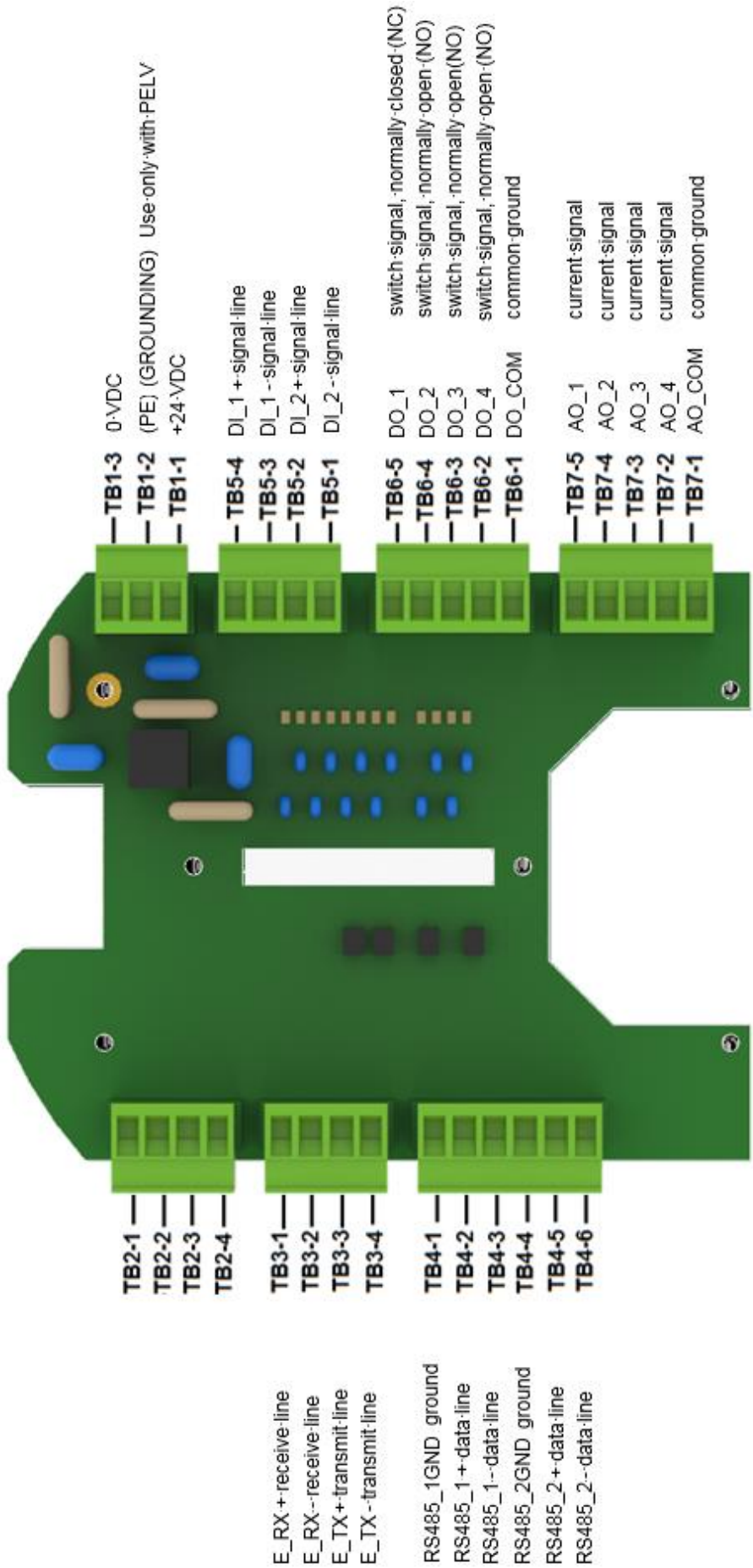

Figure 5.6: Connector pin assignment

5.4.4 Connection to other devices and parts of the plant

Connection diagram examples for sensors and devices with which GasLab Q2 can be connected are shown below. This can require special parameterization in enSuite.



For detailed information on parameterization, see chapter 8 and online help. Here, only the minimum required settings are displayed in keywords.

Ethernet

For data communication connections via Ethernet, a cable type according to Category 5 (Cat 5) is recommended; the maximum cable length is 100 m as already mentioned. The connection is made via terminals TB3-1 to TB3-4 in the connection box of the GasLab Q2.

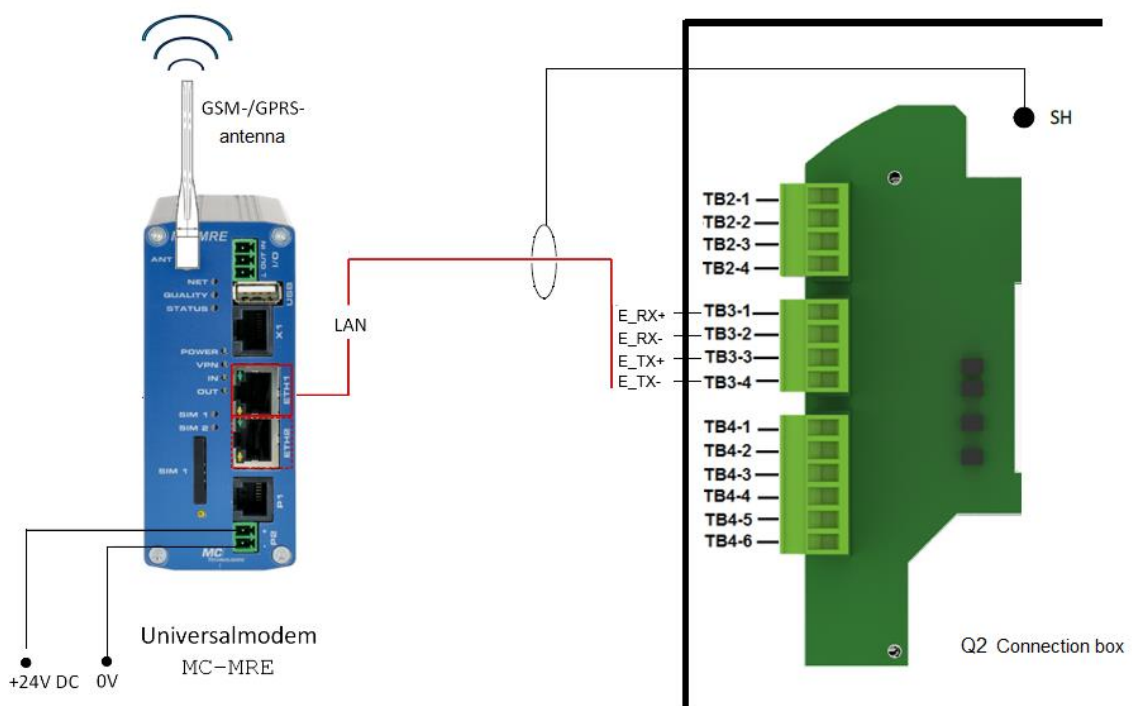

Figure 5.7: Example LAN / Ethernet connection



Before using this interface, different settings are required in addition to the wiring. These can be carried out on the device (see chapter 7.3.8). The setting via enSuite is also possible. Please refer to the notes in chapter 8 and the online help.

Parameter branch: GasLabQ2 - Basic system - I/O - Board 0: CPU

Serial interface RS485

Connection examples are other measurement devices, devices for post processing and evaluation, PLC systems etc. Depending on the device, the connection varies (see the dashed line in the following example). The ground (0 V) is either connected directly to the device / system or connected to GND. There are 2 interfaces available.

The following requirements apply to the wiring:

The shield of the connection line is connected at exactly one location (preferably at the Q2) via the cable entry or the FE connection. Resistance to resting potential generation is necessary (at any point). Each $470\ \Omega$ between **R/TA** (Q2 terminals TB4-2 port 1 and TB4-5 port 2) and **+U** (of the connected device) and between **R/TB** (Q2 terminals TB4-3 port 1 and TB4-6 port 2) and **SGND** (Q2 terminals TB4-1 port 1 and TB4-4 port 2). For cable lengths of more than 200 m, bus termination resistors of $120\ \Omega$ between **R/TA** and **R/TB** are recommended at both ends of the cable. For the GasLab Q2 side between terminals TB4-2 and TB4-3 for port 1 and between TB4-5 and TB4-6 for port 2.

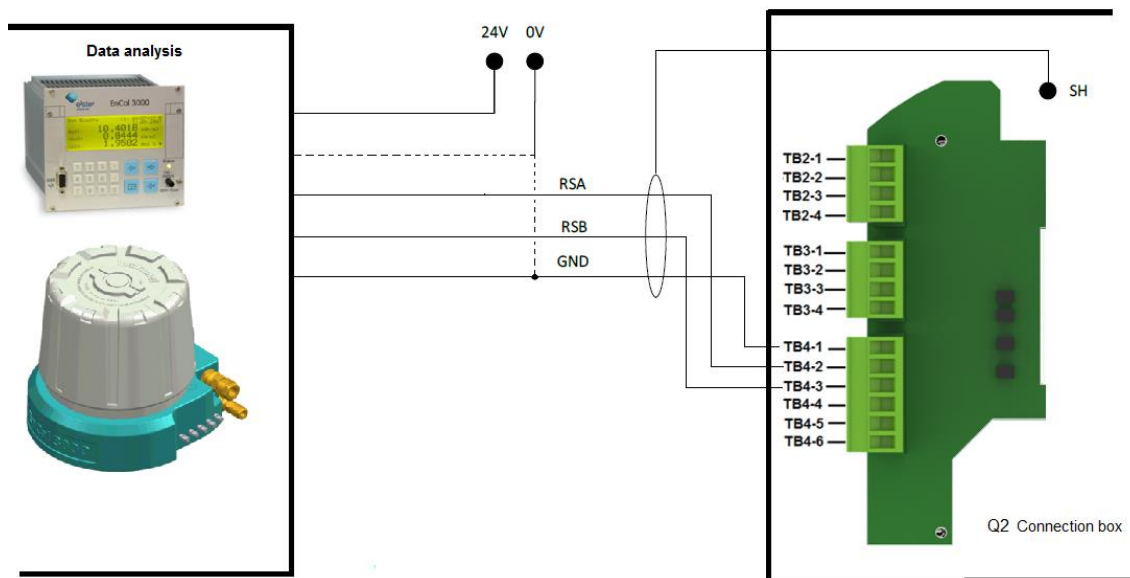

Figure 5.8: Example RS485 connection

Before using this interface, different settings are required in addition to the wiring. These are possible via enSuite.

Parameter branch: GasLabQ2 - Basic system - I/O - Board 0: CPU



On the tab parameters, set the following values:

- the type of CH1 (terminals TB4_1 to TB4_3) or CH2 (terminals TB4_4 to TB4_6) from "Unused" to "Protocol channel"

Please refer to the information in chapter 8 and the online help, which contains the necessary information to further define the parameters.

Digital inputs

Available are two electrically isolated inputs, supplied from the device. The maximum supply = feeding voltage is approx. 9 V. The shield of the connection cable is connected in one place (preferably at the Q2) via the cable entry or the FE connection. The figure on the next page shows the corresponding terminals in the connection box.



Before using this interface, it is necessary to set various enSuite settings in addition to the wiring. Set in the parameter branch "GasLabQ2 - Basic System - I / O - Input channels" the type from "Unused" to "Message Input" or "LF pulse Input".

Please refer to the notes in chapter 8 and the online help, which contain the necessary information to further define the parameters.

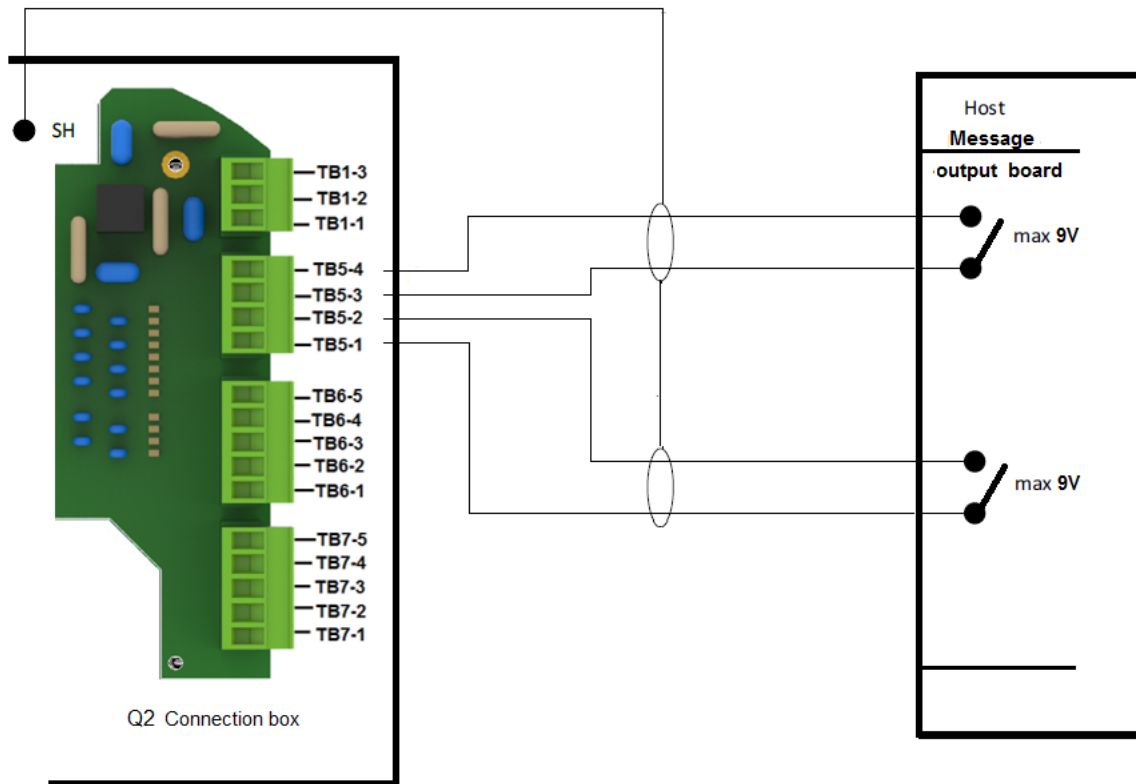

Figure 5.9: Example connection of the digital inputs

Digital outputs

There are four digital outputs (electrically isolated passive output circuits). The following figure shows the terminal assignment in the Q2 connection box.

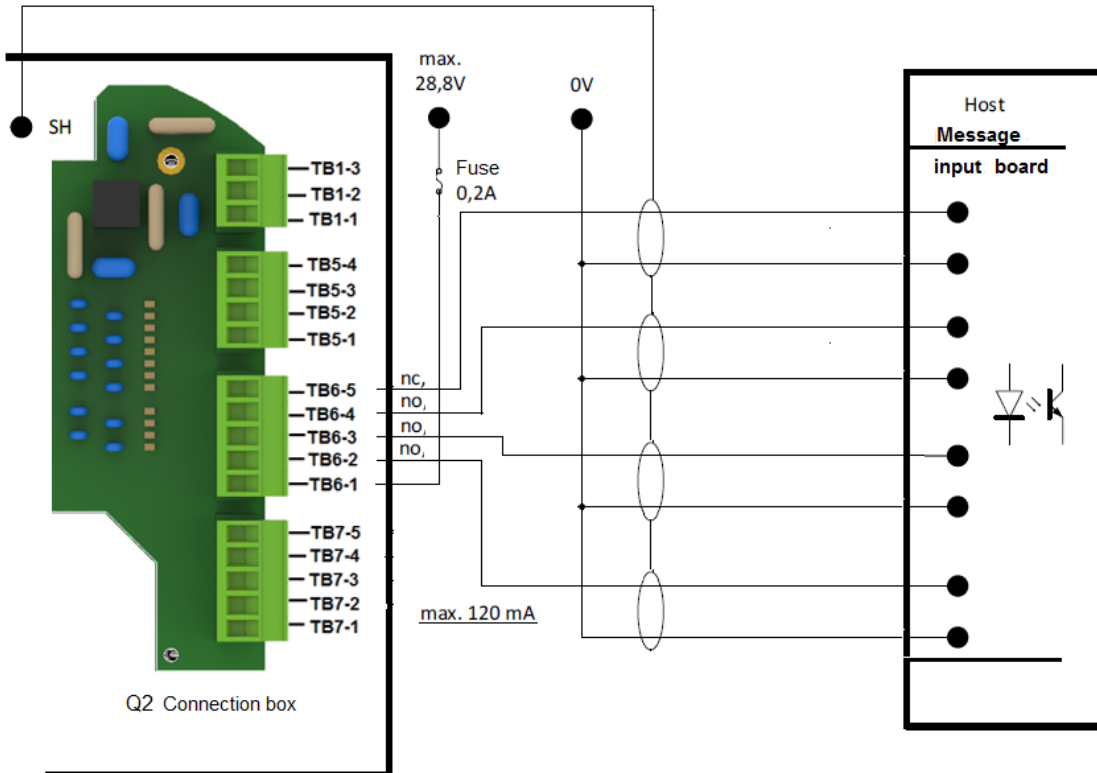

Figure 5.10: Example connection of the digital outputs

The output on TB6-5 is a normally closed (nc); the other outputs are normally open (no). The maximum cable length is 250m. The shield is connected at exactly one point (preferably at the Q2) via the cable entry or the FE connection. The maximum load per channel is 28.8V DC/120mA. The maximum pulse rate is 25 Hz.



Before using this interface, it is necessary to set various enSuite settings in addition to the wiring. Set the type from "Unused" to "Message output" or "Pulse output" on the tab in the parameter branch "GasLab Q2 - Basic System - I / O - Output channels".

Please refer to the notes in chapter 8 and the online help, which contain the necessary information to further define the parameters.

Analog outputs

There are four commonly electrically isolated active output circuits ("common ground" / short-circuit proof) with 0 or 4 to 20 mA- available. The maximum cable length is 500m. The shield is connected at exactly one point (preferably at the Q2) via the cable entry or the FE connection. The maximum supply voltage is approx. 9 V. The maximum permissible load is 390 Ω The figure below shows the terminal assignment in the Q2 connection box.

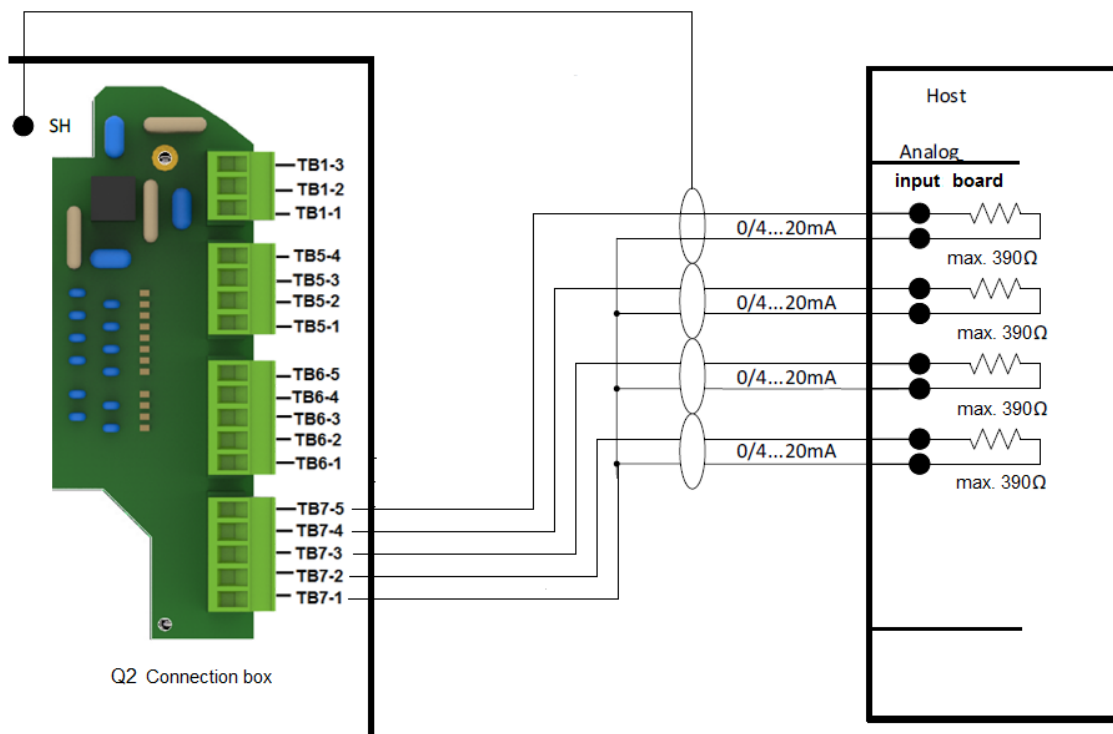

Figure 5.11: Example connection of the analog outputs



Before using this interface, it is necessary to set various enSuite settings in addition to the wiring. Set on the tab in the parameter branch "GasLab Q2 - Basic System - I / O - Output channels" the type current output for the relevant channel (in the range I1 + I-, I2 + I-, I3 + I- or I4 + I-).

For the current range parameter, set the desired current output range: - 0 to 20 mA or 4 to 20 mA.

Please refer to the notes in chapter 8 and the online help, which contain the necessary information to further define the parameters.

6 Commissioning and decommissioning

This chapter briefly describes the main points for commissioning and decommissioning of the measurement device. All newly delivered devices already have a basic or factory parameterization and can perform the measurement task. If necessary, customer- and system-specific settings must be applied.



Do not perform any of the work described in this chapter if you do not have the permission and necessary instructions from Elster GmbH or their representatives!

Ne pas effectuer les travaux décrits dans ce chapitre, si vous ne disposez pas de l'autorisation ni des instructions d'Elster GmbH ou de ses agents!

In addition, commissioning may only be carried out by qualified service people. Elster GmbH offers the necessary device-specific service and commissioning training courses.

The presence of a fiscal verification officer is required for final commissioning of the device, when it is used for the scope of fiscal metering.



In this case, the requirements of the current authorization must also be observed. This is ensured by a corresponding file in the device, which adapts the settings. This file will make the device settings compliant. Details please see chapter 8.

6.1 Requirements for commissioning and operation

All safety notes and warning instructions in chapter 2 have to be observed, and the device has to be mounted and installed according to the instructions in chapter 5. In particular: the gases are at the correct pressures and temperatures and an calibration gas cylinder is connected correctly to the device. The composition of the calibration gas mixture is stored in the device. (see chapters 7 and 8)



Power supply and communications are carried out properly. The delivery is less than 1 year (battery charge more than 20%). The device housing is completely closed. No condensation water inside the device*.

L'alimentation et de la communication sont correctement effectuées. La livraison a été effectuée il y a moins de 1 an (batterie chargée à 20 %) Le boîtier de l'appareil est complètement fermé. Aucune condensation sur l'appareil.

* Ensure that the Q2 is operated without condensation. Check drop formation in the connection box. Open according to chapter 6.2.2, after checking, close the box again. If condensation has formed, it first must evaporate. In case of doubt, wait for approx. 12 hours or please contact the Elster GmbH.



The rules in force concerning sealing and housing seal must be observed in fiscal operation.



Regulations for explosion protection and safety must be observed, especially during commissioning in an area with a potentially explosive atmosphere.

Les exigences relatives à la protection contre l'explosion et à la sécurité doivent être respectées, en particulier lors de la mise en service dans un environnement potentiellement explosif.

6.2 Start-up and normal operation

If the device is supplied with electric power, the start-up procedure begins automatically. The first step is the booting of the computer and the heating of the sensor block. The current temperature of the sensor block (called TSB) is displayed during this time on the display that appears.

If the TSB has reached the operating range at 70°C, the delay and flushing times are also displayed and an automatic operational calibration is executed. After this procedure, the device switches automatically to normal operation "Analysis".



The devices are supplied with a factory parameterization, which enables the device to be commissioned with low accuracy deviations without further changes.



The factory parameterization setting also defines the start up behavior described above. For change requests, see chapter 8, or get in contact with the Elster GmbH.

With the factory parameterization settings, the raw values from sensors are processed and reported as well as monitoring and recording tasks are implemented. The power consumption of the heating is reduced. Only the power, which is required to maintain the temperature at measurement conditions, is used for heating after the start-up.

This function (normal operation) is displayed on the screen of the device. The measuring system is applied to various natural gases and measures these gases in continuous flow every second.

The GasLab Q2 has an extra heater for use at temperatures around the freezing point and below. To protect the device against overheating, this function is only available up to a housing temperature of + 13 °C. With the factory parameterization, the extra heating is automatically switched on at 0 °C, with a switching hysteresis of 2 °K. The heating function is set and modified via the parameterization software enSuite. Please see chapter 8 for more details.

Perform all work in the specified order to avoid any damage and malfunctions on the device.

Steps for start-up		
1.		Check the condition of the system and the connections.
2.		Open the operational calibration gas cylinder (setting 0.2 MPa (g)).
3.		Open the process gas (PG) (setting 0.15 – 0.5 MPa (g)).
4.		Switch the power supply on; it automatically starts the start-up and heating process. The built-in operation panel is activated. The heat up time of a cold device can be up to an hour.
5.		After the TSB reached the operational value, the software performs the further parameterized steps (see chapter 8). The final step is the measurement mode "analysis"; this is displayed on the screen.
6.		Check the gas flows into the flow meters and customize them, if in the valid range, see chapter 6.2.1. Also check the settings for calibration gas mixture and automatic operational calibration, and correct them if necessary. See chapter 8.3.4 Q2 now works continuously and the commissioning is complete.

6.2.1 Checking and customizing the gas flows

If you have carried out the above steps 1 to 6 and the right LED of the device flashes red, the flow of the process gas has to be adjusted. Given that the local conditions are unknown and may differ with regard to the factory settings, it is possible that the internal pressure is not sufficient. In this case, try to increase the pressure of the process gas until it reaches 0.2 MPa (gauge). If this is not possible or the pressure is even higher, gently twist the right needle valve until the LED lights up permanently.

If the bypass is used, its flow rate must also be adapted to the conditions of the installation; this is possible with the left needle valve. If the right LED flashes or flashes again after this setting, perform a (re)-correction on the right needle valve (as described above).



The device displays all dependent values (e.g. temperature, pressure, etc.) in RED (as a fault) before they reach the measurement conditions and the right LED flashes in RED.

If no errors are currently present, the LED lights up permanently. The color depends on previous events. The values are displayed in BLACK text.

For more information → see chapter 7

6.2.2 Checking device settings and signals

A complete review of the current device parameterization can be performed by using the enSuite software with an online connection to the Q2.

See chapter 8. Parameterized output signals can be measured using appropriate measurement devices and checked in that way.

Verifying digital communications (Modbus, etc.) may take place (e.g. as a protocol analyzer). Use appropriate tools.



**DO NOT OPEN WHEN AN EXPLOSIVE ATMOSPHERE IS PRESENT
NE PAS OUVRIR DANS UN ENVIRONNEMENT EXPLOSIF
DISCONNECT POWER BEFORE OPENING
DÉBRANCHEZ AVANT L'OUVERTURE**



The unit may only be opened in a controlled environment according ISO/IEC61010-1* L'appareil ne peut être ouvert que dans un environnement contrôlé conformément à la norme ISO/IEC61010-1*

* These conditions (temperature 5°C to 40°C; humidity up to 80% at 31°C decreasing linearly to 50% at 40°C) usually prevail in residential and office spaces. In case of doubt, please read the standard or contact Elster GmbH.

6.3 Decommissioning



Without external power supply nor from the backup battery, data will be lost (e.g. archived data, device time setting). The device will not start correctly without support from Elster GmbH. // Sans tension d'alimentation externe ni alimentation interne par la batterie de rechange, les données seront perdues (par exemple, les données d'archives, les paramètres du temps). Le dispositif ne démarre pas correctement sans le soutien technique d'Elster GmbH.

Please proceed in the following order if you want decommissioning the measurement device and reuse it later in another location:

Steps for decommissioning		
1.		Turn off the voltage (power supply and communication) and secure it against turning back on.
2.		Turn off all gas flows from (process gas / calibration gas). Also prevent the accidental opening of the valves by way of suitable measures.
3.		Allow the device cool down to ambient temperature and disconnect all gas lines and immediately close all outputs and inputs with plugs to prevent water from penetrating or dirt getting into the Q2
4.		Open the connection box in a non- hazardous area and remove all cables (power and communication) by unscrewing cable glands or cut cable if sealed. Dismantle the device mechanically.
5.		Observe the instructions on storage or disposal, regardless of whether you have carried out all the steps above.



Devices that are stored after decommissioning must basically be stored like new devices. We recommend replacing the battery with a new one if the Q2 has not been supplied with voltage for more than 1 year. After two years without power supply, the battery charge is less than 20% and an exchange by the Elster service personnel is required. After 3 years the battery is completely discharged. Please contact Elster GmbH if you want to store the device longer.

Elster, being the manufacturer, will take care of proper disposal of the device once the operational life expires. Send the Q2 to the following address:

Elster GmbH
Steinern Straße 19–21
D - 55252 Mainz-Kastel, Germany



If you don't want to send the device back, the laws for the disposal of industrial waste must be strictly observed! Si vous ne voulez pas retourner l'appareil, les lois applicables pour l'élimination des déchets industriels doivent être strictement respectées!

7 GasLab Q2 displays and operating the device

After switching on the power supply, the device begins the start process. When the start process has been completed, the unit provides an overview of the state of the measurement on the screen, which is also called display. Both LEDs above the display light up continuously. For normal analysis mode, it is not necessary to change this view; current values (for part. wet gas) are always displayed here.

Some operating modes called **Operation** and special functions make it necessary to change into other displays. You can view the other device functions with their displays from the "**Home**" display, the main branch point of the device.

General information and rules are listed below. Their details are explained in the next chapters.



Regardless of the current device display, you only have to select a maximum of two keystrokes (☐ and/or ☐ bottom right on screen) to view the basic display after startup again. This basic display is the Q2 main display. It is also automatically switched on during longer operating pauses.

Three types of access are possible:



1. Operation with local control panel of the unit
2. Operation via the network with remote control panel

These two types can be used to access all standard functions of the device. Only influence parameters cannot be changed.

3. Operation via enSuite

This type of access can be used to operate additional functions like reading or changing parameterizations, archive readouts or watching "Live data and trending" (For further information ⇒ see chapter 8).



The following applies for each type of access:

To protect important settings and to simplify the parameterization, the device has a user management with password protection. (No passwords assigned upon delivery)

Only one user can be logged in at the same time.

Your own password can be created and changed at any time on the device.

Changes already performed and not yet adopted are discarded after logging out.

Login, logout and password changes are written in the log of device.



Training and seminars

To facilitate the operation of the measuring device or to use all its individual options, Elster GmbH offers training courses and workshops. If interested, please use the contact address on page 3 of these Operating Instructions.

7.1 Concept of the operation panel

The control panel, another term for the previously described HMI parts, can be operated in various ways. Local on the device or remotely, using a web browser or via the software enSuite. Depending on the type of access, the appearance changes slightly. For example, partial bounding lines or additional icons are displayed that are missing in other access types. The concept is explained below.



It may be that you do not see the red box or a symbol in the bottom line if you use another access type but the Operating Instructions. This is not a mistake. More info on operation and application is provided in this section and the following chapters.

Parameters affecting the results (official) cannot be changed on the control panel.

7.1.1 Local and remote operation

The device has an interactive screen (part of HMI, see chapter 4.3). This operation panel is used to display the measurements, as well as how to use the various modes of operation such as process gas measurement, calibration, and date setting. For this purpose it is equipped with 7 touch fields (see red areas in the figure, not visible on the device). Two status LEDs above the display indicate the device state.

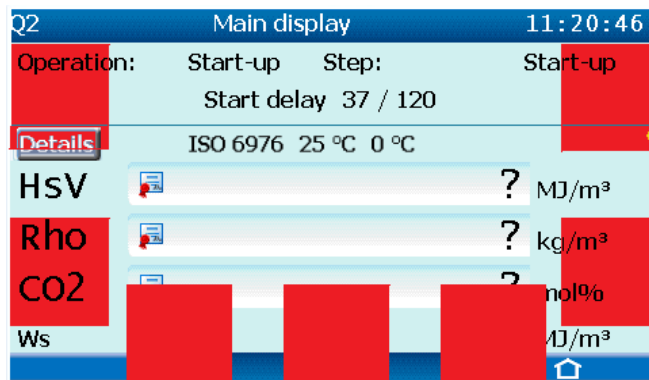

Figure 7.1: Interactive screen on the device



The lighting of the interactive screen switches itself off if no contact is made for a set period. After a new touch, the display becomes visible again.

A graphic illustration of the local operation panel, the so-called “**Remote operation panel**”, can be displayed on a PC. The **Remote operation panel** allows operating the device from a distance, like the local operation on the device. The LED’s located on the device (over the display) are also shown in the graphic illustration and behave like the real life counterparts.



The remote operation panel mimics the touch of the interactive screen by using the mouse. Click on the appearing arrows in the areas outlined in red.

The connection to the device is done via Ethernet by using a web browser. To do so, enter the IP address of the device in the web browser. The IP address is part of the used device parameterization. The parameterization defines these basic settings.

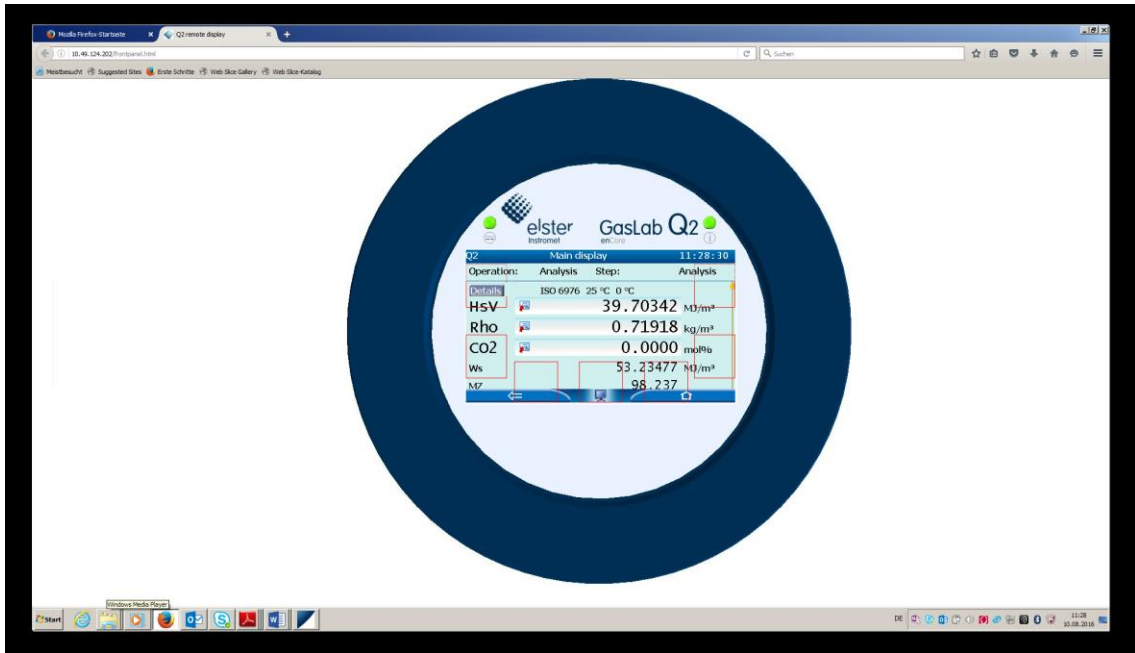

Figure 7.2: PC view of the remote operation panel with browser



The remote operation panel is also provided by enSuite. → See chapter 8

7.1.2 Navigation in operation panels and displays

The following section describes in general the menu navigation and operation locally and remotely by means of examples. A first overview of the structure of the display is shown in figure 7.3. The details will be explained later in the Operating Instructions.



Figure 7.3: Overview of display parts

If you operate **in front the device** and use your finger to go around the edges of display (the red areas in figure 7.1) or if you operate **the remote operation panel** and click in the displayed red boxed areas using the mouse (see figure 7.3), left/right and up/down arrows are displayed and a confirmation arrow appears on the lower side of the display.

These inserts are called “**Overlay keys**” If there are no additional touches or clicks, these arrows will be blended out again. There are only slight display differences between navigation on the device and remotely

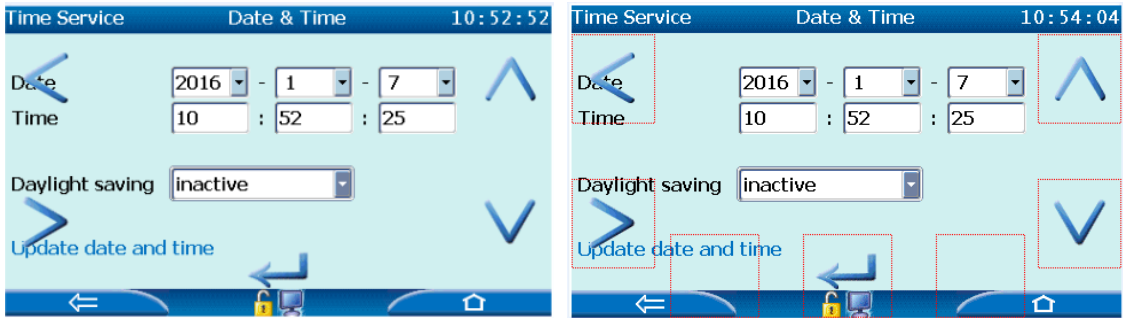

Figure 7.4: Overlay keys local and remote

Note the following information regarding the overlay keys:

In order to exploit the screen in full, overlay keys appear only when needed for as short as possible.

No overlay keys are displayed after starting the device. When the (invisible) sensitive areas are first actuated, only the key symbols are displayed, without any further function execution. If no further action occurs, the symbols disappear after 30 seconds. If the area is operated again while the overlay key is visible, the corresponding function is executed. If there are no more actions, the overlay keys will disappear after 10 seconds. The invisible keys will still execute the last shown function for next 20 seconds. The keys reappear when actions occur during this time.

If 30 seconds of no activity have elapsed, the procedure must be started from the start.

Because some displays are too long to be shown completely, a small yellow diamond on the right side shows which part of the list is displayed. Using the overlay keys (arrow keys); you can scroll through the list of displayed values.

Operation:	Analysis	Step:	Analysis
N2	0.0000		mol%
C6H14	0.0020		mol%
C7H16	0.0005		mol%
C8H18	0.0000		mol%
CH	0.0488		mol%
C2+	0,4571		mol%
C6+	0,0026		mol%

Further functions of the menu navigation are selectable points of the screen like **hyperlinks**, **actions**, **drop-down lists**, and **fill-in fields**. You can select all entries with the override buttons. The selection is then highlighted in gray. In figure 7.3 "Details" and in figure 7.4 "Daylight saving" are selected; in the following examples "Device monitor" and "Time" are selected. Not all displays have this option.

Hyperlinks and **actions** are shown in blue color in the displays.

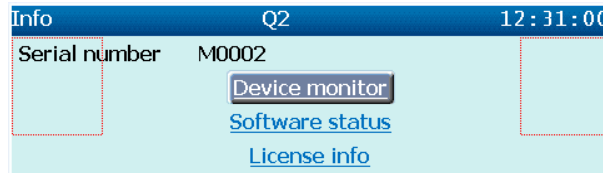

With **hyperlinks**, you navigate through the screens by activating the corresponding display, which is automatically called.

You perform a specific function using **actions**. Dialogs for changing values appear.

A **drop-down list** can be identified by a triangle on the small gray box next to the value; **fill-in fields** show their values in white boxes.

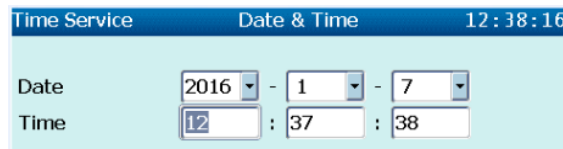

With **drop-down lists**, you choose between predefined values.

With **fill-in fields**, you have the ability to change shown values.

Selectable **hyperlinks** and **actions** are blue underlined, e.g. "**Software status**" and "**License info**" in the first figure on the page or "**Gas components**" in the following figure. If there is nothing underlined, the point cannot be selected (in the example "**Start**" is not underlined so the calibration functions cannot be started or executed). By using the overlay keys, you jump to the next selectable point, even if it is not in the visible area of the display. In this case, note the small yellow diamond on the right edge of display.

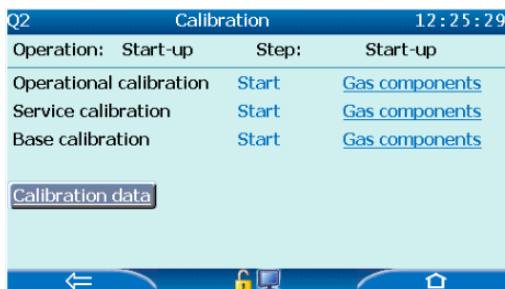

To confirm or perform the selection ("**Calibration data**" in example), press your finger into the field of the confirmation arrow in the center of the bottom line on the device, or click with the mouse into this field for remote operation panel.

There are two additional sensitive areas (buttons) at the lower edge of the display, which are available depending on the context. They change their appearance in different situations. The figure below shows the possible navigation combinations at the device (without possible icons in the middle of the line)

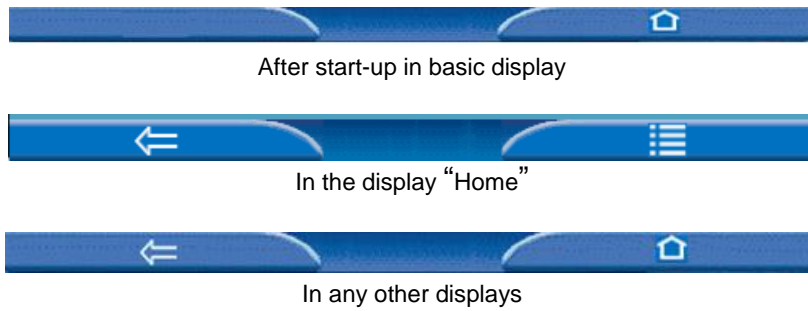



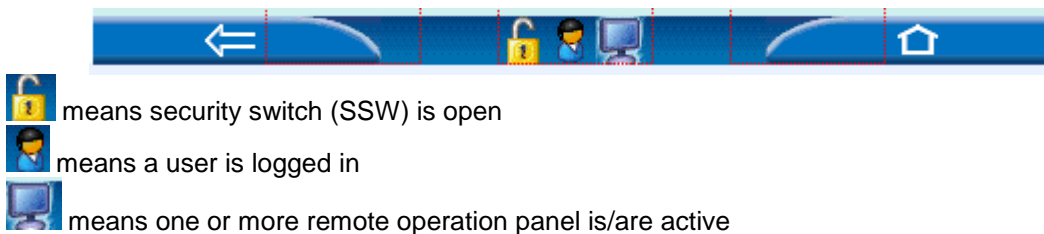

Figure 7.5: Buttons at the lower edge of the display







Generally speaking, you can jump to other displays here. Please use the sensitive (red boxed in figure 7.1) area next to the symbol for tapping / clicking. Activate  opens the display “Home”,  calls the **basic display**,  and takes you back to the previous screen.

Additional information in the form of icons is sometimes shown in the middle of the line:

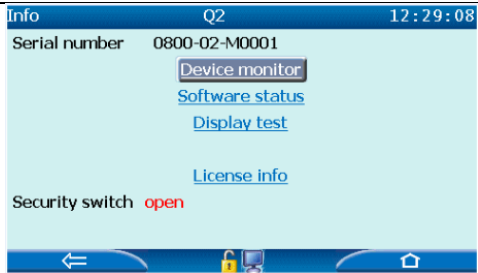

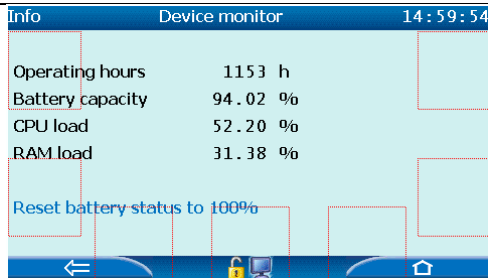
These icons are displayed only for specific situations. No icons are visible without user log in, remote operation panels and with closed security switch (SSW). Further information about this situation, and the icons will follow in the course of this instructions.

If you are in a display, there are three different navigation destinations:

	<p>1. Switch to a sub display or to a dialog (e.g. from (i)System Q2 to Device monitor)</p> <p>Touch the screen or click in the area of the overlay keys until the desired target is highlighted then press/click  (confirmation arrow)</p>
<p>2. Back to the previous display (e.g. from Device monitor to (i)System Q2)</p> <p>Touch / click the section near </p>	
<p>3. Back (from any point via Home) to Q2 Main display (for example, from Device monitor display)</p> <p>Touch or click the screen in the area  to get to Home display (Display (i)System Q2 will be skipped in this example and symbol will turn to )</p> <p>Touch or click the screen in the area  to go to the basic display (Q2 Main display)</p>	

7.2 Displays of the GasLab Q2

Although the **Q2 Main display** (basic display) contains all relevant information, some operations require changing the display. By using the navigation described in the previous section, each display can be reached. In addition, device dialogs and confirmation dialogs will support the navigation through the displays. Progress dialogs provide information on the success and progress of the actions.



In most Q2 displays, the current time of day is shown in the upper right corner.

Changes of displays are mostly done via a special display called **"Home"**. It is the main junction or branch point of the device. This display is explained first to provide a better understanding and an overview. Starting from the display **"Home"**, various other displays are explained and described in details.

7.2.1 Home (display overview / device language / start-up-errors)



After startup, the **"Home"** display can be shown via . Home is a special display and shows the software structure of the device. Individual pieces of software and selected other functionalities that should be easily accessible (e.g. time setting or language change) are shown as small icons in this display. These icons are labeled with the name of the associated functionality and may contain further branches.

The following figure shows the main branch point. The display called **"Home"**. The structure of displays is tree-like, which means a sub- item of a module can in turn have sub-items and side branches.

Only the **"Home"** content of delivery status is described here. You can change the available entries and structure in the display, if similar rights exist with enSuite (⇒see chapter 8).

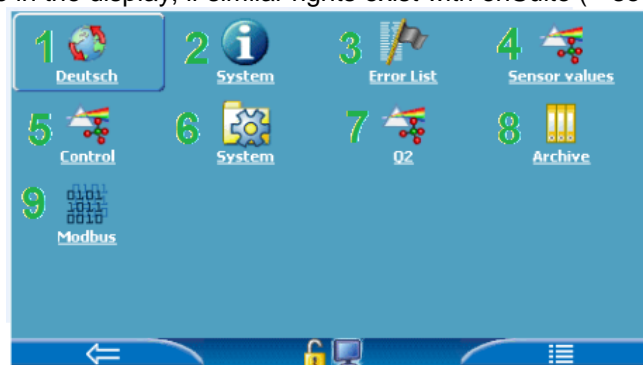









Figure 7.6: Branch points display "Home"



Additional Navigation options in Home display

Selecting an icon (with overlay keys) in the Home display will open it and display the functions grouped in that icon. If there is no separate functionality behind the icon, the selection immediately shows the corresponding main display of the function.

Displays and branching overview "		
1		With the " Globe ", you can switch to the language which is shown under the symbol. If English is your main language, this function is an option.
2		The display " Info Q2 " lying behind this symbol provides an overview of "Serial number", "Device monitor", "Software status", "Display test" and "License info". In addition, the status of the security switch (SSW) is indicated. ⇒ See also chapter 7.2.2
3		The display " Error List Main display " lying behind this symbol provides a complete list of all active / non-active (not accepted) errors and warnings. ⇒ See also chapter 7.2.3
4		The display " Q2 Sensor values " lying behind this symbol provides the currently incoming measurements (raw values) of the transmitters or sensors from the Q2. ⇒ See also chapter 7.2.4
5		The display " Q2 Control " lying behind this symbol offers the possibility to select "Calibration" or "Verification" (test gas measurement) and to disable the touch screen. For more information ⇒ see chapter 7.2.5
6		Behind this symbol is another branch point (System Display) This display offers the option to enter the displays Time Service, Users, Logbook, Audit trail and I/O . For more information, ⇒ see chapter 7.2.6
7		By selecting / activating this symbol, you jump to the Q2 Main display (display after startup) For more information, ⇒ see chapter 7.2.7
8		The Archive Main display is lying behind this symbol and offers the possibility to select between different archives and to look at them. For more information, ⇒ see chapter 7.2.8
9		The Modbus Main display behind this symbol offers the option to choose between different registers and view these registers. For more information, ⇒ see chapter 7.2.8

Change of Device Language (optional)

To change the device language, execute these steps on the display "**Home**":

Process steps „change language of Q2		
1.		Select the "Globe" (the alternative language is displayed below the symbol) and confirm the selection.
2.		The language has changed (visible on the labels of the symbols); the language used beforehand is shown under the "Globe"



Up to two languages are possible. English is always the second language. If you use English as first language, the device is completely in English. GasLab Q2 always starts in the first language. Please inform Elster GmbH if you want to change the pre-installed first language. Displays and menus, for example, format of date and time, are established depending on the current parameterization and the current language.

If the language is changed, all data of the device are renamed or reformatted and displayed in the current language.

7.2.2 Display Info Q2 (System)

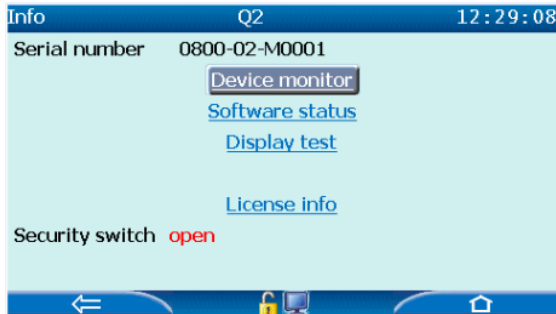
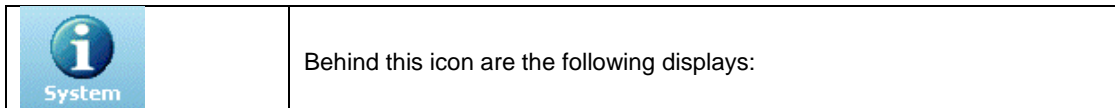

The display shows the serial number of the device and the status of the security switch (SSW), a sealable (official) hardware interruption. This safety prevents illegal changes to fiscal and important device settings, or software downloads. See chapter 7.3.10.

Apart from that, you are also able to branch to the following functions:

Figure 7.8: Display Info Q2

The **Device monitor** displays information concerning operating hours and battery capacity (charge) as well as CPU- and RAM-load. The battery is mainly is used or power is drawn from the battery, when the device is turned off. After repairs or servicing (with battery change), a user with appropriate rights can reset the battery status to 100%.

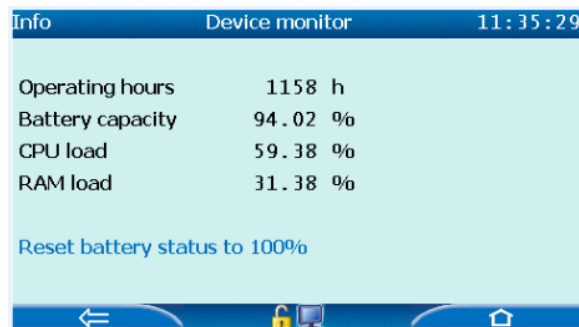

Figure 7.9: Display Info Device monitor



The battery (Li/SOCI2 ½ AA Voltage 3.6 V) must be replaced when the battery capacity (charge) is less than 20%. The exchange is performed by Elster authorized personnel, because the housing must be opened.

La batterie (Li / SOCI2 ½ AA Tension 3.6 V) doit être remplacée lorsque la charge est de moins de 20 %. L'échange est effectué par le personnel de service d'Elster, car l'ouverture du boîtier est nécessaire.

An empty battery may sometimes lead to a loss of the measurement data that was calculated and saved. The device will then not start correctly without support from Elster GmbH.

Une batterie vide peut conduire à la perte de données de mesure calculées et stockées. L'unité ne démarrera pas correctement sans le soutien technique d'Elster GmbH.

Software status

This display shows the identification data of all software components that are included in the device. These credentials consist of the name of the respective software components, the version number and checksum. Behind "Last check" the top line shows the time of the reading for the following information. The first column lists the name of the software components of the system. These names are selectable hyperlinks and branch to further sub-display (component pages) with information about this piece of software.

The second column shows the software version number of the component and the associated checksum is listed in the third column. During operation, the actual checksums are calculated and compared to the corresponding reference values. If a checksum is marked in red, the last check has failed, i.e. a deviation was found. An error is generated in this case see also chapter 11.2.

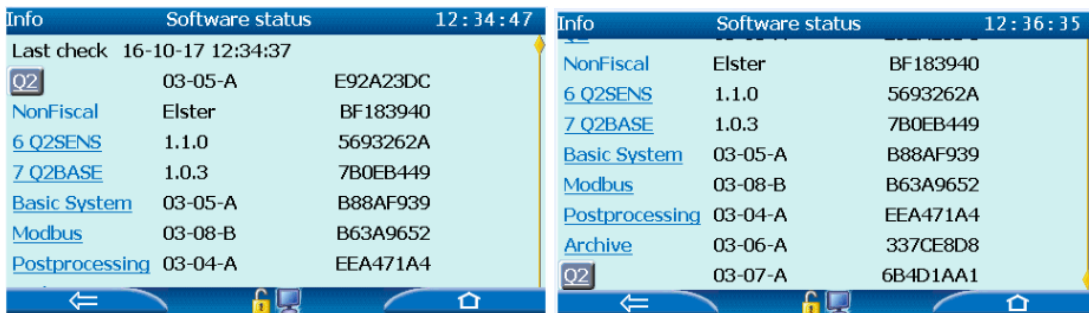

Figure 7.10: Display Info Software status

Examples for component pages.

You will find information about: Last check/ SW part/ Name/ Version/ Total code/ Param.total

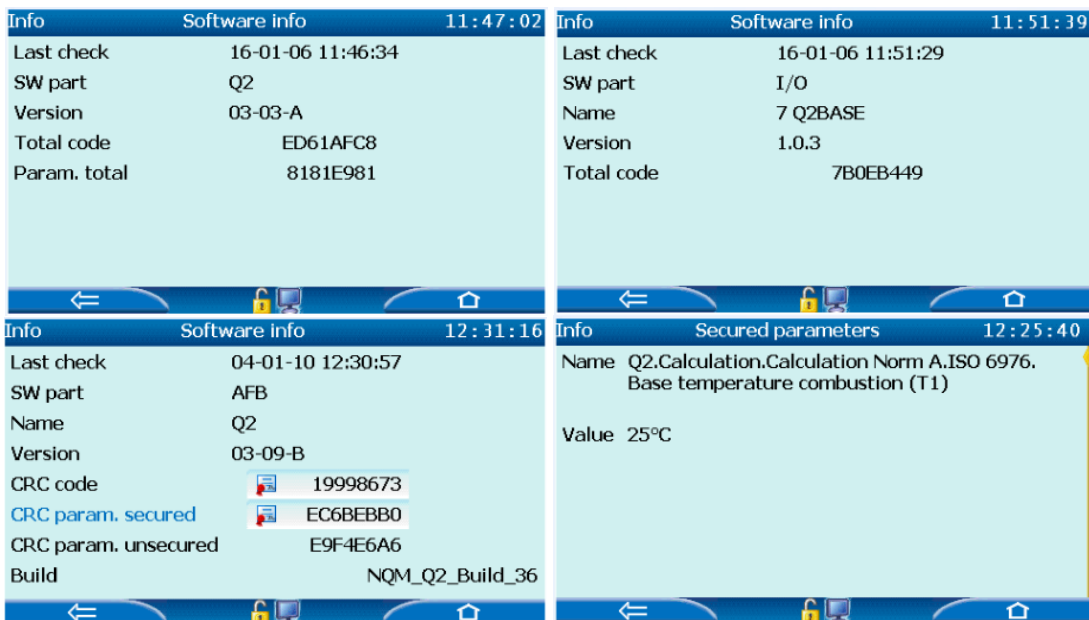

Figure 7.11: Displays and sub-displays Info Software info



Figure 7.11 only shows examples. If you operate the device e.g. non-fiscal, you will not see the screen "Secured parameters". As the example shows, the component pages are not uniformly structured.

The display “**Software status**” shows the abbreviation of an approval file in the second place in the list. This file defines which parameters are saved before modification in order to operate the device in accordance with customer specifications or approvals. It is also possible to operate without an approval file. In this case an entry “**NonFiscal**” is shown at this place, as it is shown in the example above. If the device is operated with an “**Approval file**” and closed SSW, relevant parameters are saved.



If you want or have to protect parameters with an approval file, please contact Elster GmbH. It will then close the SSW and extend the software to use this function. ⇒ See chapter 8.4.6.

If the device status is compliant with the approval file, black text on the display is shown; if there are deviations the text is in red color. By activating the displayed hyperlink of **approval file** the appearing sub display “**Approval**” provides more details about the file.

Display test

With this action, a display appears on an ongoing basis; all pixels of the display are turn on and off. This way, you can check whether the display is working in an error-free manner.

- ▶ Stop the test with (back) or (home).

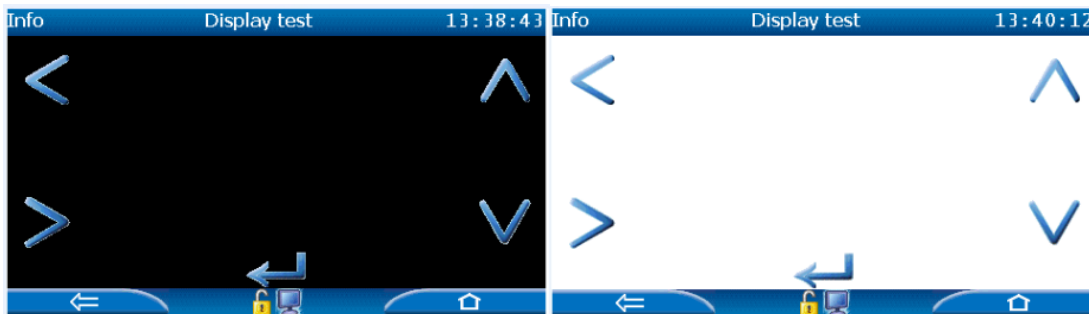

Figure 7.12: Display Info Display test

License info

The link opens the following display with information about licenses, copyright, and rights.



Figure 7.13: Display Info License info

7.2.3 Error list main display

	<p>The device manages the warning and alarm messages in this list and registers them in the logbook. Which warning and alarm messages occur, depend in detail on the parameterization of the device. The list is behind this icon.</p>
---	--

 **After the opening, the list is "held" to avoid re-sorting the entries. Errors can only be accepted and removed if this is in accordance with the previously defined acceptance procedure, see chapter 8.**

The list is sorted in ascending order by date and time. The last event before opening the display is at the top. Primarily, all entries (alarms / warnings) that are currently pending or waiting for acceptance are shown. The events are identified as follows

Identification	Definition
< black font color >	Message or signal type event
< yellow font color >	Message or signal type warning
< red font color >	Message or signal type alarm

Figure 7.14: Display and kind of errors

The following figure explains the details of the display.

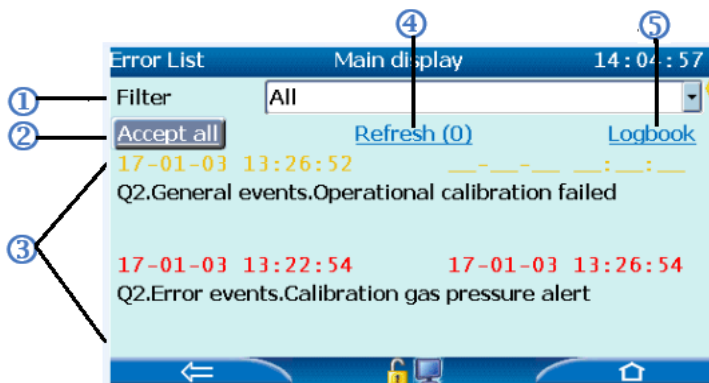
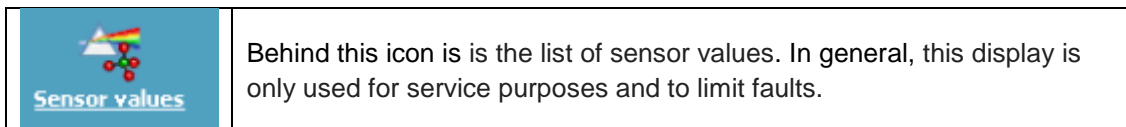

Figure 7.15: Display error list main display

- ① **Filter selection.** In the first line, you can select by using the drop-down list to show only errors from selected device parts
- ② **Accept all** Displayed no longer actual errors have been accepted at once. Accepted errors are removed from the error list. Messages which are pending or filtered were retained.
- ③ **Area for displaying errors:** The beginning of the error is displayed on the left side and the end (if usable) on the right side. In the next line the the relevant message is listed. (If more than 2 events are included in the list, scrolling can be performed. (Yellow diamond at the right edge)
- ④ **Refresh** button for refreshing the display. The directly after their opening "held" Error List can be updated.
- ⑤ **Link to Logbook display:** With "Logbook" a change to the "Error List Logbook" is possible ⇒ See chapter 7.2.6

7.2.4 Display sensor values



Q2		Sensor values		13:41:38
Operation:	Analysis	Step:	Analysis	
UIR1			235.37	mV
UIR2			641.79	mV
UIR3			607.87	mV
UIR4			599.12	mV
PI			1.0072	bar
TSB			70.00	°C

Figure 7.16: Display Q2 sensor values

You will see a complete list of all sensor values in the following table:

Sensor signal	Use / meaning	Sensor value range
UIR 1	only for internal arithmetic operations	some 100 mV
UIR 2	only for internal arithmetic operations	
UIR 3	only for internal arithmetic operations	
UIR 4	only for internal arithmetic operations	
PI	Pressure only for internal arithmetic operations (environment + measuring unit [ca. 160m bar])	Ambient dependent
TSB	Temperature Sensor Block	approx. 70°C
UW11	only for internal arithmetic operations	some 100 mV
UW12	only for internal arithmetic operations	
UW21	only for internal arithmetic operations	
UW22	only for internal arithmetic operations	
PU	Ambient pressure (internal monitoring)	Ambient dependent
TP	Board temperature (internal monitoring)	Ambient dependent
PW1	only for internal arithmetic operations	Some mW
PW2	only for internal arithmetic operations	
TM1	only for internal arithmetic operations	around 100°C
TM2	only for internal arithmetic operations	
TB1	only for internal arithmetic operations	around 68°C
TB2	only for internal arithmetic operations	
TH1	Housing temperature (internal monitoring)	Ambient dependent

7.2.5 Display Control (calibration / verification / touch)

	Behind this icon is the following page, which enables you to select “calibration”, “verification” or “disable touch”.
---	---

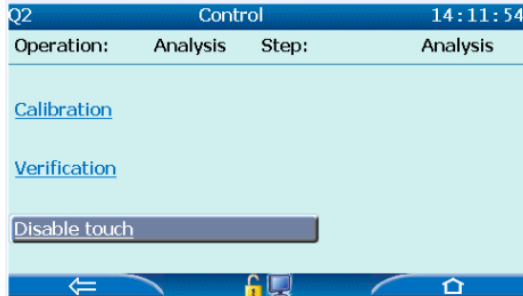

Calibration enables a further branch to the calibration sub-display.

Verification allows the start of the verification and other branches.

Disable touch interrupts the operator input (local and remote) for the count down time shown behind the link. It can be used, for example, to prevent temporary inputs caused by screwing on the sand protection.

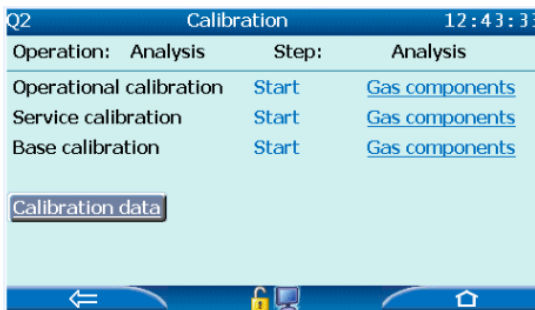

Figure 7.17: Display Q2 control with Sub-displays Q2 calibration and Q2 verification



Displays and function of “Operational calibration” ⇒ Chapter 7.3.3.
 Displays and function of “Service calibration” ⇒ Chapter 9.2.
 Branching possibilities and function of “Verification” ⇒ See chapter 7.3.4
 The displays of “Base calibration” are only required by Elster and not described any further here.

The display **Calibration data** contains internal values caused by the operational calibration and deviations to the previous settings.

The display **Gas components** shows all used calibration gases and provides information about the gas quality. With appropriate user rights, you can also make changes here.

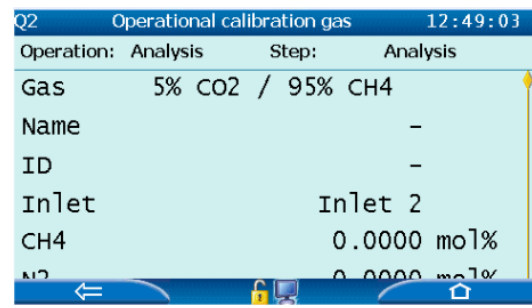
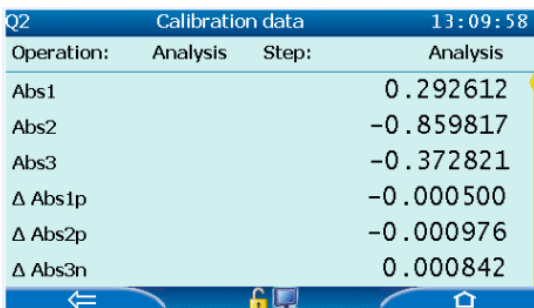
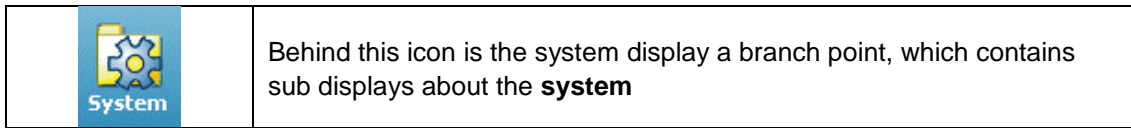

Figure 7.18: Display Q2 calibration data and display Q2 calibration gas

During normal operation, the display calibration data is not required as it is only used for servicing and maintenance purposes and to facilitate the error analysis. The information on the **gas components** is only required when the gases are changed and explained in more detail in chapter 7.3.3.

7.2.6 Display system (device) (time / user / logbook)



You can use this branch point to access the following sub-displays:

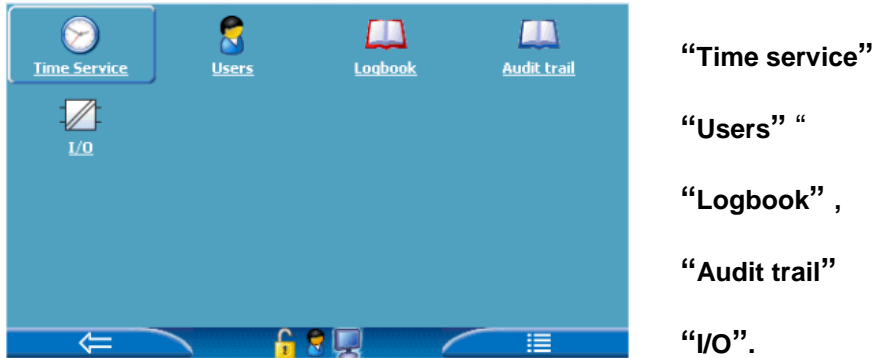

Figure 7.19: System display



The **Time Service** for issuing and changing the device's internal time has up to four standard displays. Depending on the user's login (see chapter 7.3.6) and the parameterization (see chapter 8), these displays change. The first display is the “**Time Service Main display**”

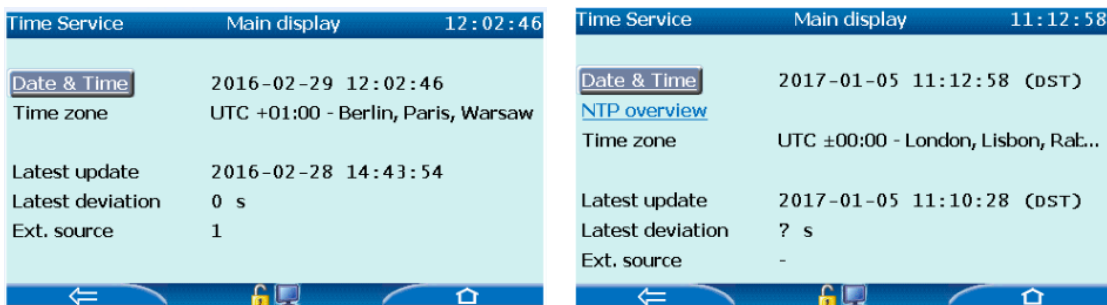

Figure 7.20: Time service main display without / with NTP synchronization

The **Time Service Main display** shows the **date** and the **time** (also called **system time**). The abbreviation (DST) means daylight saving time and is displayed only if the current time is in the daylight saving time. The Network Time Protocol (NTP) is a standard for synchronizing clocks in computer systems. The **NTP overview** link is only displayed if NTP synchronization is activated in the Q2 device. Information on activation and function⇒ See chapters 8 and 11.2. In addition, the following is displayed:

Time zone: Geographical location

Last update: Time stamp of the last time change.

Last deviation: Deviation (in seconds) for the last time change

Ext. source: Number of external time source for the final time synchronization

For the non-logged-in or logged-in users, without the right to change the device's time, the display "**Time Service Time Synchronization**" opens as second display after "**Date & Time**" has been activated.

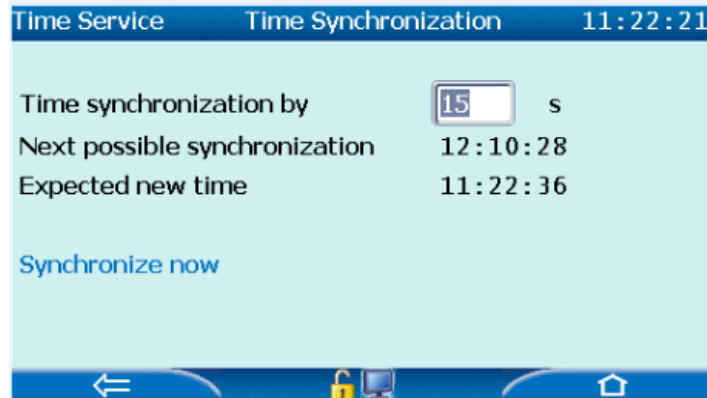

Figure 7.21: Time service time synchronization

Time synchronization by:	inserts the seconds in the field at which the system time should be changed.
Next possible synchronization:	displays the next possible time for further synchronization. Calculation takes place after a synchronization based on the parameter "synchronization interval"
Expected new time:	in this line, the time service continuously calculates the new system time
<u>Synchronize now:</u>	with this action (if selectable), the expected new time will be used as system time.

For the logged-on user, with right to change the device time, the display "**Date & Time**" opens as a second display after activation of "**Date & Time**".

The type of representation or the order of the display (parameterizable ⇨ see chapter 8) depends on language and time stamp format. See the following examples:



Figure 7.22: Display Time Service Date & Time with different time stamp formats

The "**Date & Time**" display enables action to set the system time and to make the selection for the application of (DST) daylight saving time.



More information about these displays and the functions ⇨ see chapter 7.3.9.

The last optional display, **NTP overview**, is only displayed if the NTP synchronization in Q2 device is enabled. Information on activation and function, ⇨ see chapters 8 and 11.2. It opens after activation of **NTP overview** in the time service main display.

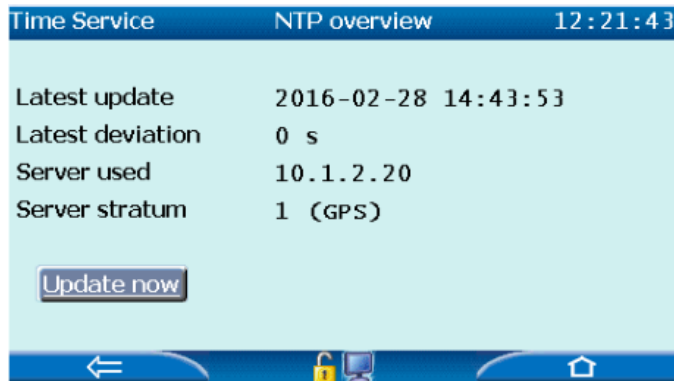
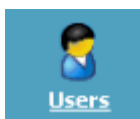

Figure 7.23: Display Time Service NTP overview (option)

The display presents the action: **Update now** to synchronize system time with NTP server. In addition, the following entries are still displayed:

- | | |
|-----------------------|---|
| Last update | Time stamp of the last time synchronization via NTP. If synchronization has already been carried out, in the display, the exact time of this synchronization can be seen (date, time, time zone). |
| Last deviation | Deviation (in seconds) for the last time synchronization via NTP specifies how many seconds the device's internal clock deviated from the standard time in the last synchronization |
| Server used | Name or IP address of the NTP server used for the last time synchronization |
| Server stratum | Stratum values of the NTP server used for the last time synchronization. (number of computers up to the time reference in the NTP hierarchy). |



The **user management** only presents the “**Users Main display**” on the device or on the remote operation panel. Login and logout is done via this display, which changes its appearance accordingly. After successfully logging in locally, local actions to apply or discard the modified parameters and logout are displayed. The bottom line of all displays contains a user icon during the time a user is logged in. See the following figures.

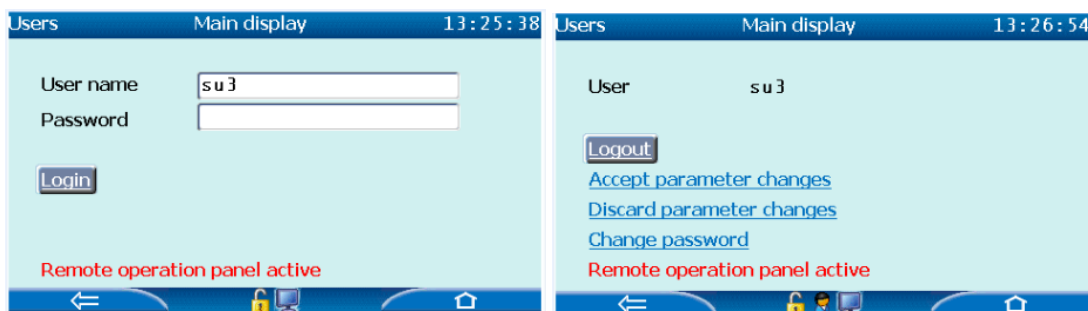



Figure 7.24: User's main display without/with login

In addition, the logged in user can change his password. The display also provides information whether a **Remote operation panel** is active. Only one user can be logged in to a device at a time. Either the **Users Main display** shows the **Login** action or the **User** (name SU3 in the right example above) that is already logged in the device is displayed. This occurs e.g. during the transfer of a parameterization to the device.

 **For more information** ⇒ see chapter 7.3.5



The **Logbook** (Error List Logbook see figure below) shows stored incidents. Whenever an event becomes active or ends, its state change is recorded in the logbook. The logbook can contain up to 10,000 records; if the log is full, the next entry overwrites the oldest record.

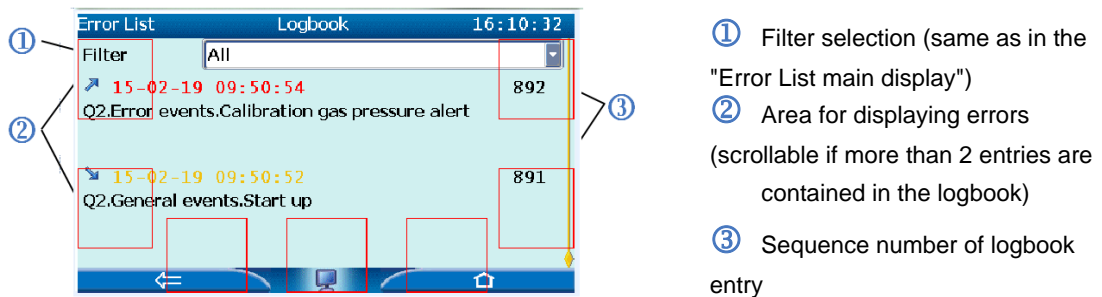







Figure 7.25: Display Error List Logbook

Each event is represented individually and numbered on the right side. The small arrow in front of the date indicates the beginning of the event (top to bottom) or end of the event (top up). See following table.

Identification	Definition
	Signal / message is coming
	Signal / message is going
 < black font color >	Signal / message type event
 < yellow font color >	Signal / message type warning
 < red font color >	Signal / message type alarm



The **Audit trail** is a protocol archive. It is located in the basic system and thus exists in all Elster device types. In the left drop-down list, it is possible to choose a selection between **general** and **fiscal** audit trail. General audit trail and fiscal audit trail differ in the type of archived data.

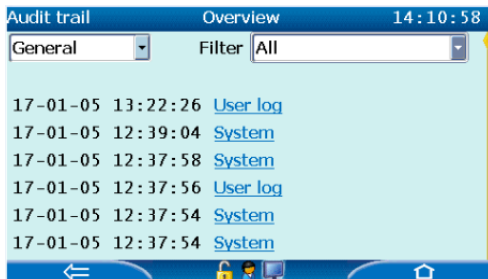

Figure 7.26: Display general audit trail overview

In **general audit trail**, the change log events recorded can be displayed more clearly with a filter in the right drop-down list. There is a choice between:

“All” (filter not used),

“System”

“Parameter change”

“User log”

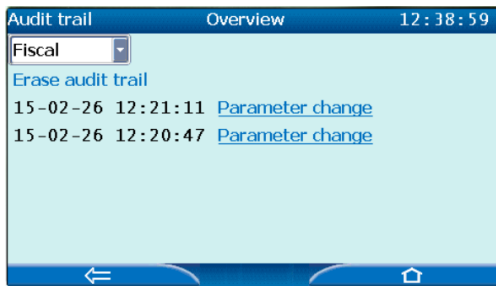

Figure 7.27: Display fiscal audit trail overview

In the **fiscal audit trail**, parameters that can be changed, even if the security switch (SSW) is closed, are recorded if the device is used for billing purposes. The actions will only be recorded in such cases (closed SSW); in other cases the archive stays empty. This part of archive is primarily relevant for billing purposes.

By activating the hyperlink behind the entry, the corresponding display can be viewed to see the audit trail entry in detail. See the example on the right hand side. Details of the change are e.g. date and time, old value / new value, logged-in user or part that has executed the change. The contents will be displayed in the current device language. The nature and scope of the displayed data depends on the situation and the settings in enSuite. See also chapter 8 and enSuite online help.

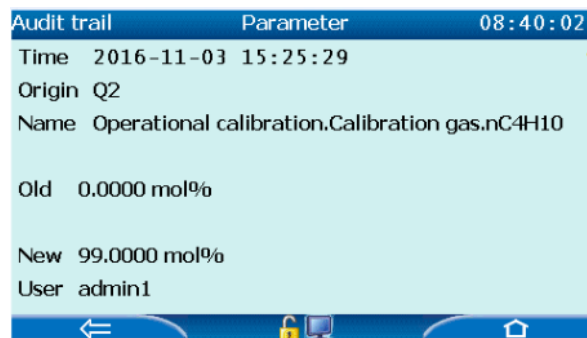

Figure 7.28: Example audit trail details



For more information about logbooks ⇒ see chapter 7.3.7



The display **I/O Overview** lists all device parts, which provides inputs or outputs and enables to branch to other sub-displays via hyperlinks. The **test mode** enables you to assign test values to individual output channels. These values are used instead of the original values.

The hyperlinks and the **Test mode function** appear depending on the parameterization. A login is required for functional use. (See chapter ⇒ 7.3.6 and chapter 8).

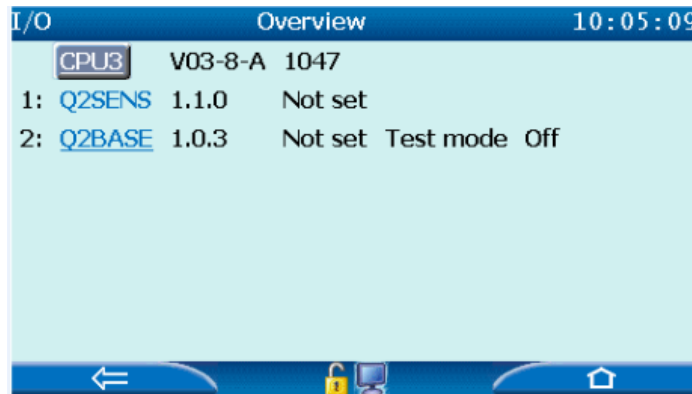

Figure 7.29: Display I/O overview

The hyperlink of **CPU3** is always present and enables branching to **Ethernet I/F** display with the network basic settings. See the figure.

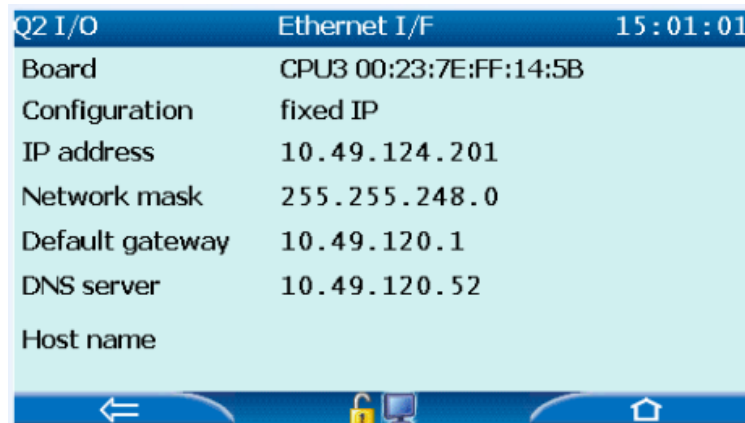



Figure 7.30: Display Q2 I/O Ethernet I/F

The display shows the internal board (CPU3) with its MAC address (00:23:7E:FE:14:5B) in the example above. If a user is logged on with the appropriate rights configuration (DHCP Mode), IP address, network mask, default gateway, DNS server and host name (name of device) can be changed. The number of changeable entries is additionally influenced by the selected / given settings.



Without login / authorization, this display is purely for display purposes. More information and options about this display; ⇒see chapter 7.3.8.

7.2.7 Q2 Main display (calculation standard)

	<p>With this icon, you can reach the Q2 main display (factory-set display after startup or reboot), alternatively use * (bottom right on home display). This display is the basic display of the device.</p>
---	---

* leads to the parameterized main display in the delivery state; this is the factory-set display.



If other displays are not used within a predetermined period of time (see chapter 8), the device automatically switches back to this basic display. There, the device always shows new measurement results in an overview.

The following figure shows the appearance of the display at the end of the start-up process (extra line for TSB and start delay is displayed), while the fields for the measurement results are filled with questionmarks.

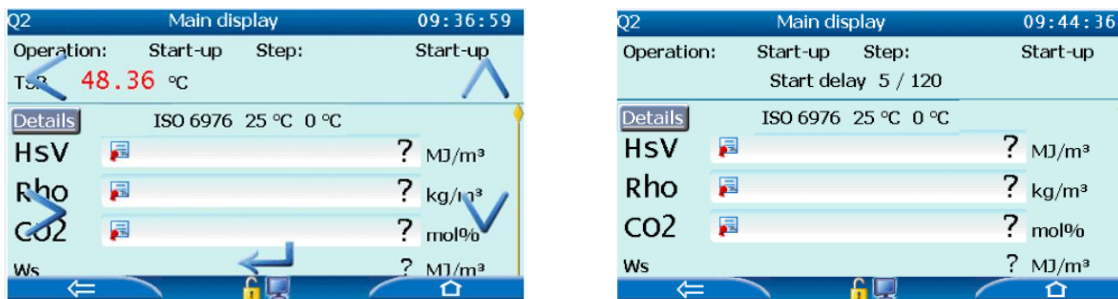

Figure 7.31: Q2 main display (during start up)

After the start-up process has been completed, the measurement result field shows values in black color. If red entries are displayed, an error has occurred. (red entries only if parameterized. ⇒ See chapter 7.4 and 8)



The appearance of the Q2 main display depends on the parameterization (see chapter 8). In the line above the results, the current standard, with the selected settings, is displayed next to "details". Usually, it is standard A. If parameterized, a link to the second selectable standard (standard B) appears at the right side of it. In this case, the overlay keys can be used to switch to the respective standard. See also examples on the following page.

The following figure is an example of the appearance of the Q2 main display in factory parameterization. In the second line on the light blue background, the calculation standard (standard A) is indicated in the middle. A standard calculation standard and the units of measurements are preset.

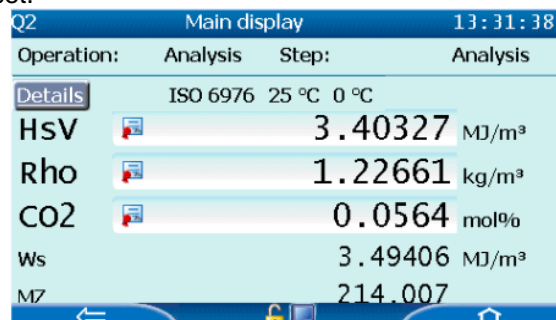

Figure 7.32: Q2 main display (factory parameterization)

In the top line on light blue background, the operating mode is indicated next to "**Operation**". Four "**Operations**" are usually used by the operator. Beside "**Step**" the actual status of device working step is shown too. Seven "**Steps**" are usually used. Following combinations are possible:

Operation	Step	Meaning
Startup	Startup	Device in boot sequence
Analysis	Flushing	Cleaning of the gas passage with gas for next measurement
	Analysis	Normal operation (result finding)
Operational calibration	Start	Wait for confirmation before beginning
	Flushing	Cleaning of the gas passage with gas for next measurement
	Gas 1	Result finding / calibration
	End	Wait for confirmation after finish or interruption of operation
Verification	Start	Wait for confirmation before beginning
	Flushing	Cleaning of the gas passage with gas for next measurement
	Verification	Result finding / verification
	End	Wait for confirmation after finish or interruption of operation



More details about the listed "operations" and "steps" are provided later on in the text.

The device still has other operating modes and steps which are not specified and described here, since they are only used by the Elster GmbH

It is possible to display a second calculation standard and switch between these standards, so that the appearance of the corresponding line is variable. See the following examples with two standards.



The current standard with its settings is shown in the middle, in the example ISO 6976 (Standard A). On the right side, a link to the alternative standard B is shown. It can be selected. The title (main display) indicates additionally, that the results of the standard A are shown in the adjacent figure.

Activate **standard B**. Use the overlay keys. By using this, following changes take place:



The text in the title (main display) changes to "Standard B" and provides additional advice. It results in standard B being shown in the adjacent figure. The second light blue line shows that ASTM 3588 is standard B. On the right, the link **Standard A** is shown, which enables again a switch.

Figure 7.33: Examples of the appearance of the basic display with 2 calculation standards



information for amendment or extension of this setting. ⇒ See chapter 8

The measurement and calculation values (results) are shown following these control and information lines.



The values shown are only valid when the system is in an undisturbed analysis mode. This is indicated by the black font of value, if the value is monitored (see chapter 8). It means that no sensor alarm is present. "Analysis" is the displayed behind "operation" and "step".

In general: No alarm is present when the status LED is permanent lit.

The Q2 main display shows:

Displayed value (abbreviation)	Meaning (of the abbreviation of value) / physical quantity	Displayed results ...
HsV (in capital letters)	Gross heating value based on volume	... in the pre-set units of measurements
Rho (in capital letters)	Density at base conditions (standard density)	
CO2 (in capital letters)	Carbon dioxide	
Ws	Gross Wobbe index	
MZ	methane number	... Dimensionless
Calculated gas analysis with 10 components and summation of C2 + components		
CH4	Methane	... in mol%
N2	Nitrogen	
C2H6	Ethane	
C3H8	Propane	
nC4H10	n-butane	
iC4H10	Isobutane	
nC5H12	n-pentane	
iC5H12	Isopentane	
C6H14	Hexane	
C7H16	Sum heptanes	
C8H18	Sum octanes	
CH	Sum of all hydrocarbons	
C2+	Ethane Σ + all higher hydrocarbons	
C6+	Hexane Σ + all higher hydrocarbons	

The first selectable element of the control and information lines is the "Details" button. It makes you able to see intermediate results which are shown in another display. Selection and activation is done again with the overlay keys.

In the display **Q2 Standard details**, interim results of the selected calculation standard are displayed. Below are examples of the appearance of this display (view after branching with “**Details**”):



Figure 7.34: Q2 Standard A details



Figure 7.35: Q2 Standard B details

The line with the information on "**Operation**" and "**Step**" is also displayed here. In the next line the calculation standard is specified in double size. The following values are calculated for **partially wet, dry, and wet gas**, respectively, for the set reference state.

Displayed value (abbreviation)	Meaning (of the abbreviation of value) / physical quantity
Hs	Heating value; molar
HsV	Gross heating value based on volume
HsM	Gross heating value based on mass
Hi	Inferior calorific value; molar
HiV	Net heating value based on volume
HiM	Net heating value based on mass
Z	Compressibility factor (Z) ,
Ws	Gross Wobbe index
Wi	Net Wobbe index
d	Relative density
Rho	Density at base conditions(standard density)
M	molar mass (of the mixture)
MZ	methane number



To view all calculations, use the overlay keys again (scroll), since the display is too long to be shown fully.

The change to the details of another standard is only possible via the main display.

7.2.8 Display Archive and Display Modbus

	<p>Behind this icon is the Archive Main display. The figures and the following notes are only examples, the actual setup is done with the software enSuite. (See chapter 8)</p>
---	---



In the first two lines, you can use the two drop-down lists to select archive-**Group** and archive-**Channel**. After selecting and clicking on **Show values** the selected archive values are displayed.

The following functions are available in this display:

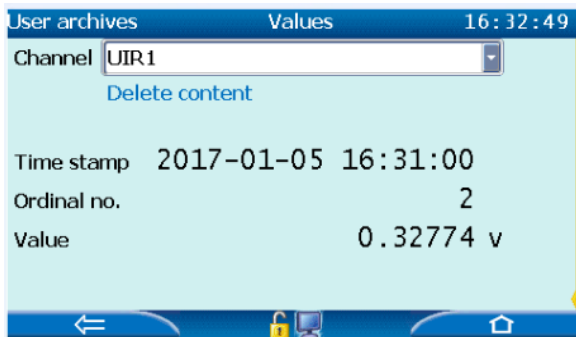

- Channel** (switch to another channel of the group)
- Delete content** (clear archive if rights given)
- Time stamp** (Date of archive entry)
- Ordinal no.** (automatically indent. number)
- Value** (archived result)

Figure 7.36: Display Archive Main display and Values

	<p>Behind this icon is the Modbus Main display The figures and the following notes are only examples. The actual setup is done with the software enSuite. (See chapter 8)</p>
---	---

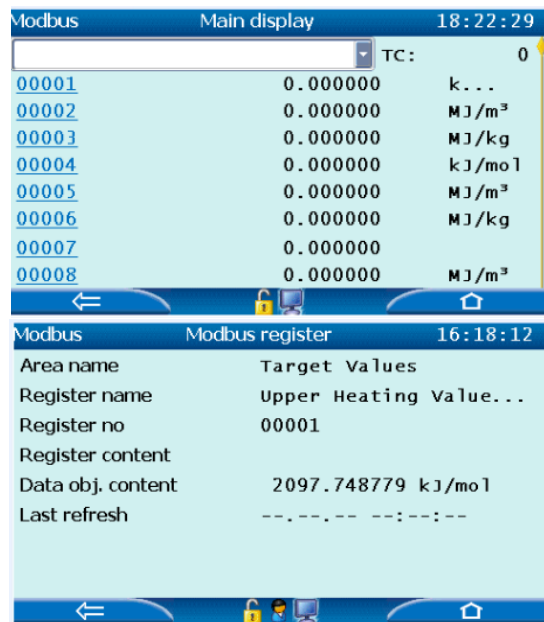

The main display contains all the registers in ascending order. Each register number is a **link** to the **detail display** in the other properties. After selecting and clicking on a link, the display appears

- Modbus register** with:
- Area name**
- Register name**
- Register no:**
- Register content**
- Data obj. content**
- Last refresh:**

Figure 7.37: Display Modbus Main display and Modbus register

 **Additional information on data logging and modbus registers, see chapter 8. Documents of the enCore FlowComputers (see www.docuthek.com) contain also additional information on this general data management.**

7.3 Operation and modes

The goal of this chapter is to make you familiar with the operation of the device and to explain the device modes. The monitoring of the devices functions, which does not require special handling, is presented first. Operating instructions for normal operation and more complex modes and functions, e.g. calibration are provided later.

7.3.1 Monitoring of the devices functions and the security switch

All main device functions can be observed and operated “on site” directly on the device’s operation panel, the interactive screen and on the remote control panel.



When several people access the device, a mutual agreement is always required, since the operation panels influence each other.

The interactive screen turns to black if no touch is made for a parameterizable time, since the lighting is switched off.

The remote operation panel is always visible. As long as the connection exists, it is updated constantly. If the connection (Ethernet) is interrupted, the last transferred values are permanent displayed. A new connection is necessary to see current values again.



A screen icon  could appear in the bottom line of all displays. This icon only appears when a remote operation panel is active. Only one icon is displayed, regardless of the real number of remote operation panels. It is possible to observe and carry out each function on all operation panels. Depending on situation some additional icons are shown too, e.g.  (someone is logged in) or  (security switch (SSW) open). See also following figures.



Figure 7.38: Displays in normal operation



Figure 7.39: Displays with logged in user



Figure 7.40: Displays while remote operation panel is active



Figure 7.41: Displays with logged in user and remote operation panel is active

 If this icon is displayed, someone has logged on and is working with the device. If it is not your login, you should also take no action to prevent the work. (See chapter 7.3.6 for more information). In fiscal metrology measurement, you have to protect settings that influence the measuring properties. This is done with the Security Switch (short: SSW). The SSW is a physical connection (jumper) inside the device.

The absence of this fuse is indicated by the icon of the padlock , which then appears on each display. In the delivery state and in "non-official operation", this connection is open and the icon is displayed.



To close the SSW, the housing has to be opened; this may only be done by authorized persons of the Elster GmbH. You can also arrange for a seal to be attached to the jumper to detect unauthorized access. Please contact Elster GmbH if you want to change the SSW status.

7.3.2 Operation mode: Analysis (automatic analysis normal operation)

After the supply voltage is switched on, and when the temperature reached the measurement requirements, the measurement starts autonomously in a continuous loop and provides values once per second. Gas flow is indicated by the flowmeter.





On the device and on the remote operation panel, the “**Main display**” is shown. „**Analysis**” is displayed on the display (for operation and step), values are displayed in black. The status LED light up continuously. Apart from the operator's intervention, the analysis is interrupted regularly by the automatic operational calibration, see chapter 8.3.4.

7.3.3 Operation mode: Operational calibration (manual)



The device must perform an operational calibration every week. This calibration usually runs fully automatically, ⇒ see chapter 8.3.4.

It is also possible to perform an Operational Calibration manually. This is only useful as long as the sensors are in an operational range. If the device is in automatic normal operation, login as described in section 7.3.6, and perform the following steps:

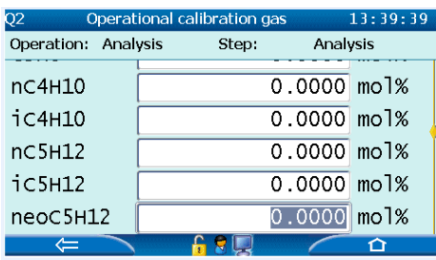
Working steps for manual operational calibration		
1.		Go to: Home  -> Q2 control  and select 
The following step is only necessary after a change in parameterization or calibration gas!		
2.		 <p>Figure 7.42: Composition operational calibration gas</p>
<p>Click on "Gas components" in the row "Operational calibration". Check or correct the calibration gas mixture using the manufacturer's analysis certificate.</p> <p>Input and changes (⇒ See chapter 7.3.5)</p>		
3.		Activate " Start " in row Operational calibration "

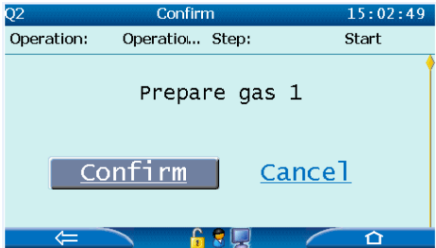
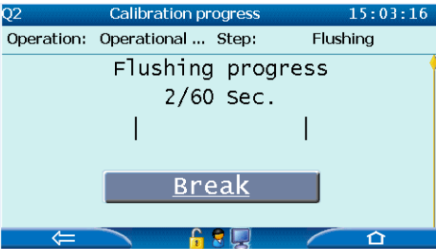
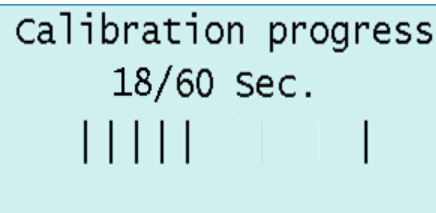
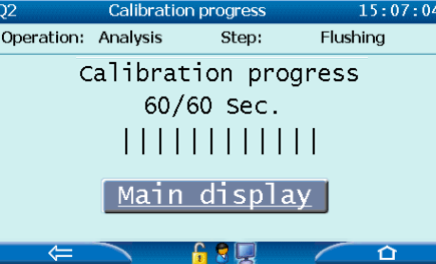
Working steps for manual operational calibration		
4.		<p>If you are sure that the calibration gas (gas 1) can be supplied properly, activate "Confirm"</p> <p>Figure 7.43: Operational calibration gas 1 confirm</p>
5.		<p>Calibration now runs automatically. The Warning "Operational calibration" is active during calibration time. First the device is flushed with calibration gas; this is indicated. The duration of the task is also displayed.</p> <p>Figure 7.44: Q2 calibration progress flushing calibration gas</p>
6.		<p>Thereafter, operational calibration gas is measured. The duration of this process will also be displayed again.</p> <p>Figure 7.45: Q2 Calibration progress gas 1</p>
7.	<p>If you decide to cancel early, you can end the operational calibration from point 5. To do so, select "Cancel or Break". The device will now interrupt the calibration process and prompts you to confirm the cancellation. After "Confirm" is activated, the device is purged with process gas and returns to the normal measurement conditions</p>	
8.		<p>After expiry of the indicated time, the calibration is completed. The analysis operation will continue with measurement. This is indicated by the status line.</p> <p>Activate the now shown "Main display" button in order to see current analysis values of a normal operation</p> <p>Figure 7.46: Q2 manual calibration ready</p>

The measurement outputs will hold (freeze) the last valid gas properties values during the whole calibration time.

The parameters for the last valid calibration will be used until a new valid calibration is performed.

"Calibration step failed" is displayed on the device and documented in the "Error List". If necessary, please contact the Elster GmbH in order to take appropriate measures, e.g. a base calibration.

7.3.4 Operation mode: Verification (special operation)

This operating mode can be used for a device check. It can be executed manually (similar to chapter 7.3.3) or automatically (see chapter 8). For this purpose, a test gas of known composition is analyzed, and the results are compared to the data from the manufacturer's analysis certificate of this gas.



The test gas must be connected to the process gas inlet for this operation. If the measurement should start the verification automatically, an automated 3-way valve must be installed in the gas flow. The analysis data of the gas must be exactly defined, a deviation causes invalid values.

The comparison can be shown directly on the displays. Navigate with the overlay keys to the **Verification** display, select **"Deltas"** in the top row. This display shows the differences between the results of the measurement and the stored data of the manufacturer analysis certificate. You will see this data when you select **"References"** on the **Verification** display. You can also see the values HSV and Rho calculated from the gas quality and the indicated standard. It is also possible to enter and / or adapt values to the manufacturer's analysis certificate, if you are logged in and authorized.

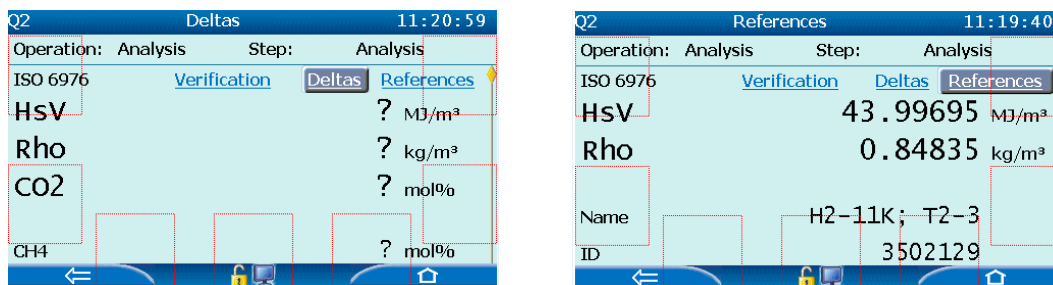

Figure 7.47: Display Q2 Deltas and References





The results obtained can also be stored in an archive, e.g. archive "Test gas". This archive must be created beforehand in enSuite (⇒ See chapter 8). If the device is working in normal analysis mode, log in (as described in chapter 7.3.6) to perform a manual verification.



The following can only be carried out if the security switch (SSW) conditions (shown in enSuite, see chapter 8) are met.

If you are logged out during execution, you can no longer access the (remote) operation panel for this operation. The last confirmed function is executed further. Log in again to continue the steps.

Working steps verification manually	
1.	Activate: Home -> Q2 control and select Verification
The following step is only necessary after a change in parameterization or verification gas!	
2.	<div style="display: flex; align-items: center;"> <div style="margin-left: 10px;"> <p>Activate "References" by overlay keys. Check or correct the verification gas using the manufacturer's analysis certificate. (Input / changes ⇒ see chapter 7.3.5)</p> <p>Figure 7.48: References with input option</p> </div> </div>

Working steps verification manually		
3.		<p>On the adjacent display, activate "Start" (If step 2 has been carried out, you have to activate Verification again)</p> <p>Figure 7.49: Display Q2 verification</p>
4.		<p>The ongoing measurement (analysis) stops, and you will see the following display:</p> <p>Figure 7.50: Display Q2 confirm (verification gas)</p>
5.		<p>Change the gas at the process input (PG) by connecting the cylinder with the test gas through a pressure regulator, according to chapter 5.3.4. Open the test gas cylinder; the cylinder pressure regulator must be customized between 0.15 and 0.5 MPa (g). Follow all safety notes when working on gas connections!</p>
6.		<p>After successful connection of the gas, completing the safety query from step 4, accept with "Confirm" (See figure 7.50). Or you can cancel the process now with "Cancel"</p>
7.		<p>After the confirmation, the device is flushed with the test gas, and then, the measurement will start. (See figure). Because there is too much data to show at once, you can scroll with the overlay keys. The information of the last or current measurement is in the lower part of the display and will be shown below the "Start" or "Stop" link.</p> <p>Figure 7.51: Display Q2 verification is running</p>
8.		<p>The verification is now running for the specified time in enSuite (see chapter 8). By selecting "Stop" you have the possibility to end the verification prematurely, and you will directly jump to step 9.</p> <p>After the time has elapsed, you will be prompted to return to the analysis mode. Select "Start analysis"</p> <p>Figure 7.52: Display Q2 verification end</p>
9.		<p>You will be asked to restore the original gas connection.</p> <p>Figure 7.53: Display Q2 confirm (process gas)</p>
10.		<p>Professionally rebuild the original connection again. Follow all safety notes when working on gas connections! Perform a leak test!</p>
11.		<p>After successful connection of the gas, accept the safety query of step 9 (see figure above) with "Confirm". The device returns to the analysis mode and the verification is finished.</p>

7.3.5 Entries and changes via device displays

Changes via device displays are always done in the following steps:

- ⇒ Log into the device
- ⇒ Perform changes / modifications and accept / confirm them.
- ⇒ Log out from device



Login and logout is done on the “Users Main display“. ⇒ See chapter 7.3.6. The accept procedure for parameter changes is done there too.

Changeable values are highlighted in white boxes, the editable fields. These editable fields appear depending on the login status and given rights. Changes are only applied and stored if the user explicitly accepted them. If the user logs out or is logged out by another event without confirming, changes already made are discarded.

Entries and changes can be made using either a drop-down list or an inserted keypad.



1. Changes with the help of a drop-down list



A drop-down list is recognized on the small gray box with triangle next to the value to be changed. The view changes after activation in the following way.



Figure 7.54: Drop-down list opened

The drop-down list is opened and provides the available values. The up and down arrows on the right margin (in the red boxes) make it now possible to select a value from the drop-down list. The selection made is grayed out (in the example 2015).

After an user action, a confirmation with the keys  , is required.

With  you accepting the changes; with  you discarding the changes.

2. Changes with the help of an expanded keypad to enter letters and numbers.



You recognize an entry field on the white background. In the example "User name" and "Password" have entry fields. The view changes after activation and shows a corresponding inserted keypad.



Figure 7.55: Keypad shown

Depending on the expected input, a keypad with letters and numbers (on the left in example) is displayed, or only a number pad will appear (on the right in example). A switch between uppercase and lowercase letters as well as numbers is done by using the "Aa" or "123" field; see left example.

The overlay keys now make it possible to select a key (button) in the field. The selection made is gray, and you have the following options:

Apply the selected value with  the keypad still open in this case. You can enter another value in this field. If all values in the field already exist, you can close the keypad with  and keep all the values in the entry field. With , you can discard the entries. The keypad closes also.

When you leave the input mode, a check for consistency is affected if a value was entered that is not useful or not allowed in the present context, the value is not accepted, and the previous is preserved or replaced by a substitute value.



Tip:

If only individual characters should be replaced, you can jump with the button  at the end of the present entry and complete it.



At the same time, the button will change too and show the following symbol . Individual characters can now be deleted from the right hand side.



If the input requires rebooting, a notification with link will appear. Rebooting is immediately executed after activation of the link. If you log out without rebooting, the changes are not accepted.

Example: Changing of IP address

7.3.6 Log in, log out, and change password at operation panel

The log in, log out, change password and confirmation or discarding of the changes is made on the “**Users Main display**” (accessible via the **Home** -  **system** -  **Users**). The identification and verification of the user by **user name** and **password** takes place in the device, i.e. the user must be already created in the parameterization (see chapter 8) of the device.



Except on the operation panel, you can then log in and log from enSuite. User management is also accessed via enSuite. For details on user management, see chapter 8.2

In factory settings, the **user names** "SU1" to "SU5" with the necessary rights is preset. The access to the highest possible permissions is managed directly by the Elster GmbH. In case of forced access outside of the rights granted, you will receive a current daily password with additional information from our support.



An event log signal is generated for each login. Only one user can be logged in at the same time! If a user is already logged in, only one logout is possible via the “user's main display”.

The “**Users Main display**” changes its appearance depending on the situation. See examples in the following figure:

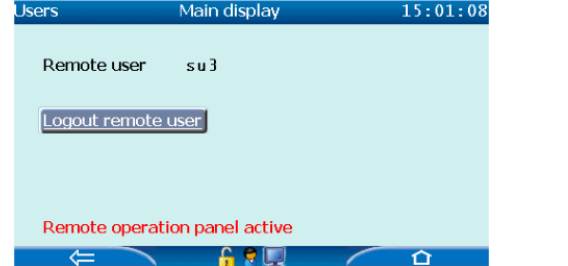
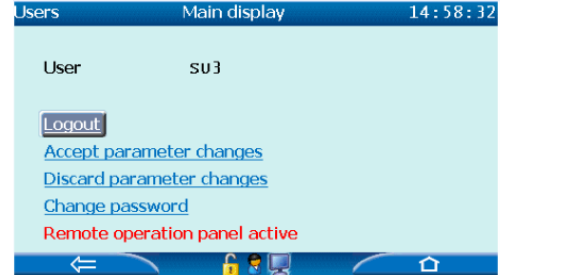
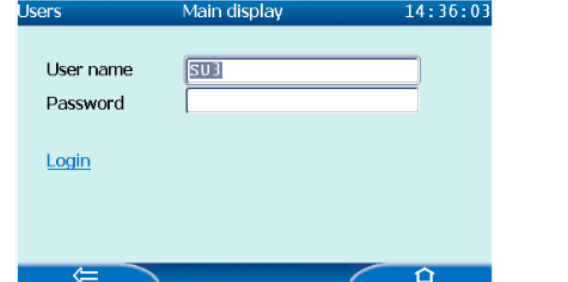
	<p>Another user operates an online parameterization. His name is displayed on top of the display field. "Login" is not possible. You can "Logout" the user (by arrangement).</p> <p>(Information about parameterization in chapter 8)</p>
	<p>A user is already logged in. His name is displayed on top of the display field. A new "Login" is not possible. You can "Logout" the user (by arrangement).</p>
	<p>No user is currently using the device.</p> <p>Field “User name” is preset with the name of the last user.</p> <p>The "Login" is possible.</p> <p>Figure 7.56: Login and logout states</p>



Remote operation panel active. This warning is always displayed in the “user's main display”, when a user is currently accessing the Q2 via the remote operation panel.

If no user is logged in “**User name**” and “**Password**” can be entered.

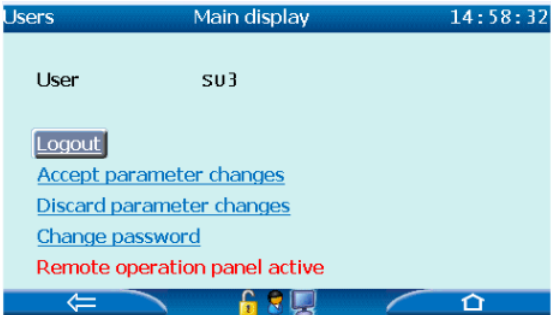
Procedural steps “Login” on the device's display	
1.	Use the overlay keys to select “ User name ” and confirm the selection.
2.	Type the user name in the displayed keypad. Not case sensitive. If the user name is filled in completely, activate  .
3.	Use the overlay keys to select “ Password ”. Edit this line as before the user name. Not case sensitive. In the display itself, each character is replaced by a *. (Optionally, this field could be blank.)
4.	Navigate to the row Login and activate this action.
5.	<div style="display: flex; align-items: center;">  <div style="margin-left: 20px;"> <p>You are now logged in, and you can use the given rights until you “logout”.</p> <p>If no actions are taken, an automatic timer (time is preset /configurable) will log you out! Learn more about this timeout due to inactivity. ⇒ See chapter 8.</p> <p>Figure 7.57: User's main display with user logged in</p> </div> </div>

After you login, you have the option of carrying out parameter changes to accept them or reject them and to change / create your password. The scope of access depends on the rights assigned.



Changes made by the operation panel are only effective after confirmation.



Procedural steps “accept parameter changes”	
1.	Make the desired changes on appropriate displays and return to the “ Users Main display ”.
2.	Navigate to the line “ Accept parameter changes ” and activate the action.
3.	The previously performed parameter changes on the device take effect
Procedural steps “discard parameter changes”	
1.	If the changes on the corresponding displays are not wanted, navigate to the “ Users Main display ”.
2.	Select the line “ Discard parameter changes ” and activate the link.
3.	The previously performed changes on the device are discarded and do not take effect.





Beware! Your password entry may be visible!

Attention! La saisie de votre mot de passe peut être vue!

As long as the icon  is displayed, all actions of all connection points can be observed and performed. Mutual observation is not noticed. The monitor icon on the bottom of the screen indicates only that the device is currently connected via an unknown number of remote operation panels. If there is a login at one connection, all of the other connections could use the rights of the logged in person.

Working steps for changing own password		
1.	<p>Navigate to row "Change password" (see figure 7.57). Activate this link and the display changes as shown.</p> <p>Figure 7.58: User's main display password change</p>	
2.	<p>Navigate to the first entry field and activate it. Enter the new password analogue to the login procedure. Please remember:</p> <ul style="list-style-type: none"> A password can consist of 3 to 10 characters from a to z (or A to Z) - alternatively, empty passwords (0 characters) are allowed and the digits 0 through 9. Special characters are not permitted. It is not case sensitive. 	
3.	<p>Navigate to the second entry-field and repeat procedure from step 2</p>	
4.	<p>When complete, select the entries with the overlay keys to Accept new password. After successful verification, the new password is effective immediately, and the display changes to the logout view. Please remember your password! To prevent activating the new password, select "Discard new password". The entry is rejected, the original password is still valid and the display also changes to the logout.</p>	
5.	 <p>A status message informs with a short display of the successful change of the password, or possibly about the cause that prevented the switch. A red font color indicates that the password could not be saved.</p>	

Log-off on device

Procedural steps „Logout at device display“	
1.	<p>Navigate to "Users Main display" (Home-System-Users). For registered users, this always contains an action to log out. If you are not logged on yourself, agree with the user who is logged on and log off. Note that parameter changes relating to the user logged off by you are discarded if they are not stored.</p>
2.	<p>Use the overlay keys to select "Logout" or "Logout remote user" and confirm the selection.</p>
3.	<p>The display changes to the login view. No user is logged on.</p>



If you have finished your work, you should log off to allow device access to other users. This will prevent that the Q2 is unnecessarily blocked for service activities and that no one is using your user data to execute changes on the device.



7.3.7 View into logbooks



To analyze large archive sections, it is more convenient to read the archives using enSuite and copy them from the Q2 into a PC. Then the data can be regarded in a table and possibly a diagram. ⇒ See chapter 8

Whenever an event is added to or removed from the "Error List Main Display", this information is also written to the **Logbook**.

The device has two logbooks "Logbook" and "Audit trail" in which events are recorded during operation as history. (fiscal part of audit trail is only used when SSW is closed) These records can also be read out on enSuite.

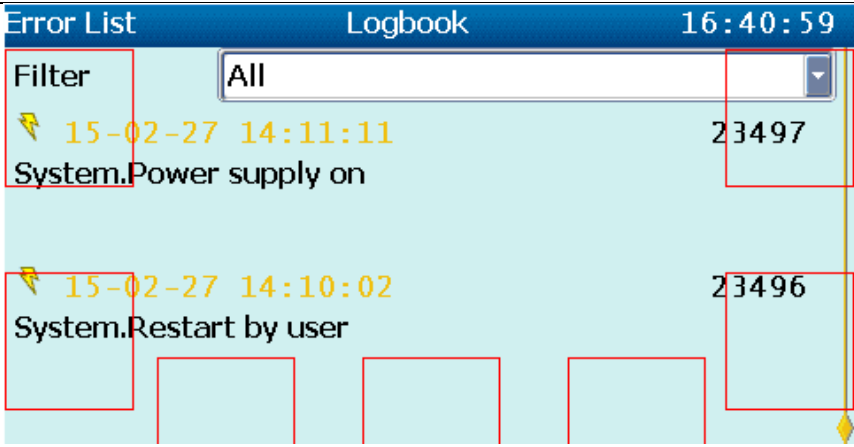
Steps to see Error List of the logbook		
1.		  Navigate via system to Logbook
2.		 Select the icon
3.		 The entries are presented in the same way as in the Error List of Main display



The archive is designed as a ring memory with 1,000 records. When the memory is full, the newest record overwrites the oldest. Its content remains after the power failure and software updates.

The header contains a time stamp with the exact calendar time at which the entry was created and an ever continuous sequence number of log entry.

The body contains the text with the information why the entry was created. This text depends on the cause and begins with the name of the software part causing the entry.

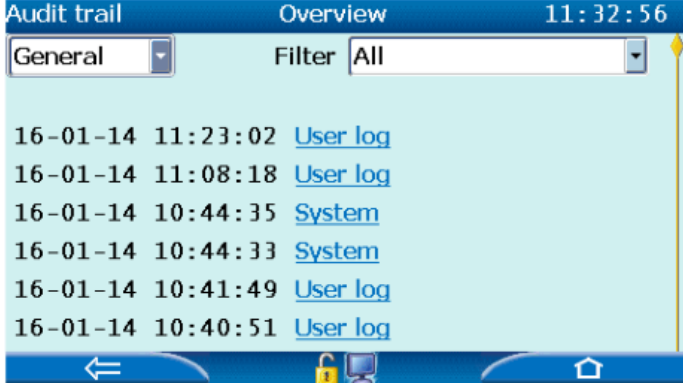
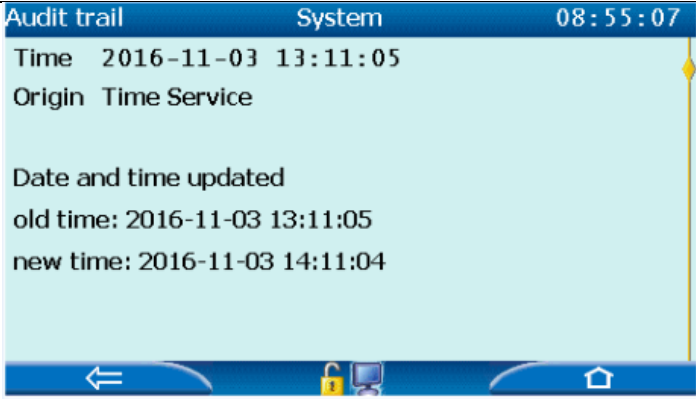

All the information of the audit trail is also stored in the log, so that the whole recorded history is visible here. The user cannot delete the entries.

Steps to display audit trail "General" part (records in "Fiscal" part are made only if SSW is closed)		
1.		Navigate via system  to  and select this icon
2.		 <p>The "Audit trail Overview" above is displayed. You can scroll through the list. Two drop-down lists make it possible to limit the overview.</p>
3.		Activate the hyperlink after the entry whose details you want to view. The contents will be displayed in the current device language and change accordingly.
4.		 <p>The detail display for the entry appears. The displayed details depend on the type of the entry and the settings in enSuite. (See enSuite online help > basic system> system> audit trail)</p>

The audit trail has space for 1,000 entries. The general part overwrites the oldest entry after reaching these 1,000 entries. If the 1,000 entries in the fiscal part are full, no further changes can be carried out to the fiscal parameters without opening the Security switch (SSW). If the SSW is open, the entries can be deleted using the display action.



A completely new parameterization (with open SSW) is also entered in the change log. Each software part is listed with a corresponding annotation.

7.3.8 Change IP address and basic network settings at device

The display **Ethernet I/F** (Ethernet interface) enables logged in users with appropriate rights to change the values of the basic network settings. See following figure and chapter 7.2.6.

If the authorization is missing, this display is only an overview of the corresponding settings.

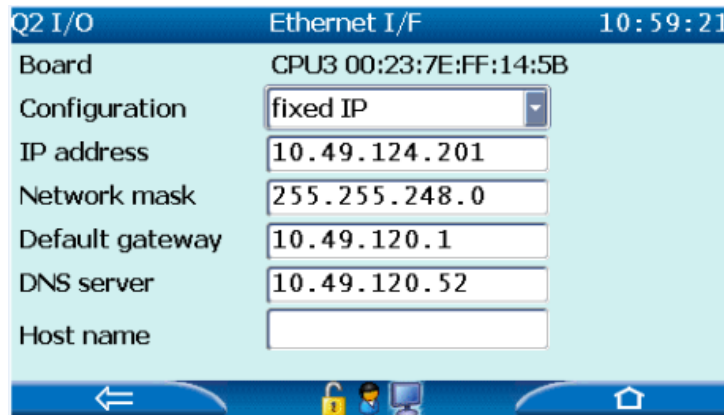

Figure 7.59: Display I/O with input option



The IP address and the basic network settings could be redefined via the operation panel or via enSuite (⇒see chapter 8).



Do not change the settings of the configuration (DHCP mode) as this function is only relevant for service and commissioning purposes!
Ne pas modifier les paramètres de configuration (mode DHCP), car cette fonction ne concerne que le service et la mise en service!

Working steps for finding /changing basic network settings	
1.	Login to the device (⇒See chapter 7.3.6)
2.	Navigate to (system) and I/O Overview . Activate action CPU3 .
3.	Register the settings and select the entry to be changed. Ask your system administrator, which parameters are to be changed. (With the activation of the field, the keypad will be displayed.)
4.	Use the embedded keyboard to enter values from the system administrator field
5.	When you finished all changes, reboot the device to apply the changes. Use the on-screen action OK&Reboot . The modified data will be used after the restart. See figure. <p>The screenshot in step 5 shows the same 'Ethernet I/F' configuration screen as in Figure 7.59, but with the IP address field '10.49.124.255' highlighted in blue. The 'Ok&Reboot' button is now visible at the bottom right of the screen. The time is '11:34:17'.</p>
If you are leaving the page - before the changes are applied, your changes will not take place	

7.3.9 Update the system time on the device

The system time (device internal permanent calendar with date and time) is saved on a battery-buffered clock module. The time information or the system time is therefore also available after switching the device off and on again. Changing the system time is the upper term for both the synchronization and the adjustment of the date and time. The system time can be set in the “**Date & Time**” display. For this purpose you need the corresponding rights, and the security switch (SSW) must be switched according to the parameterization. Synchronization enables the **Time Synchronization** display and can be carried out by all users.

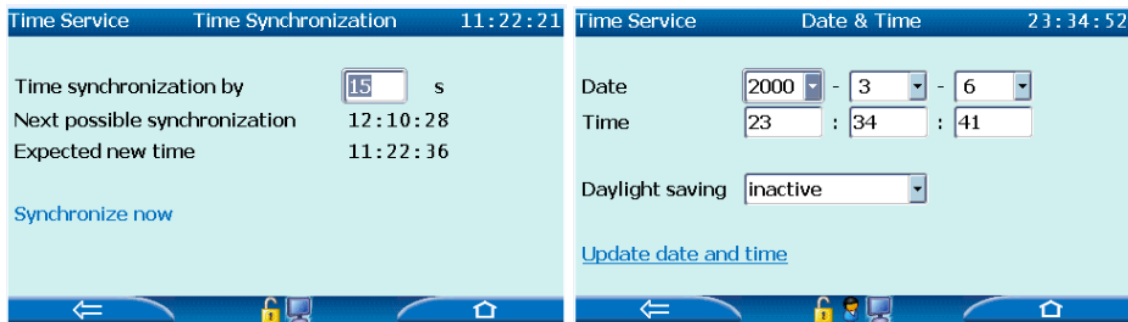

Figure 7.60: Displays to update the system time on the device or on remote operation panel

Procedural steps for time synchronization	
1.	Open the “ Time synchronization ” display (System >Time Service > Date & Time) without login.
2.	Enter the seconds (field after Time synchronization by) to synchronize the system time. Positive and negative values are allowed. The field only accepts values within the parameterized synchronization window.
3.	Check the status of “ Next possible synchronization ”. If now is shown, you can synchronize the system time (step 4). Otherwise, wait until the specified time is reached.
4.	Activate the Synchronize now action, the expected new time is taken as the system time

For further information on the settings and parameter settings of this function, see chapter 8 and the online help from enSuite.

Procedural steps for updating date and time	
1.	Login and open the display “ Date & Time ” (System >Time Service > Date & Time).
2.	Set the current date and time using the overlay keys and drop-down list.
3.	Activate if possible the “daylight saving” field. This is only possible if enSuite is configured the appropriate setting. Then select between <ul style="list-style-type: none"> • Active and non-active. The system time of the Q2 device is in daylight saving time. • Inactive -the system time of the Q2 device is in normal time. Automatic switching between summer time and normal time is not a part of the factory settings. For information on setting the time with enSuite, see chapter 8.
4.	If the entries are entered and correct, select/activate update date and time . After activation, a status message is briefly displayed at the bottom of the screen and the new time setting is being used. A red font color indicates that the update failed.

If the NTP time synchronization is enabled (deviating from the factory setting) you have the additional display "**Time Service NTP overview**", see following figure. (for more information ⇒ see chapter 8 and **the online help** of enSuite)

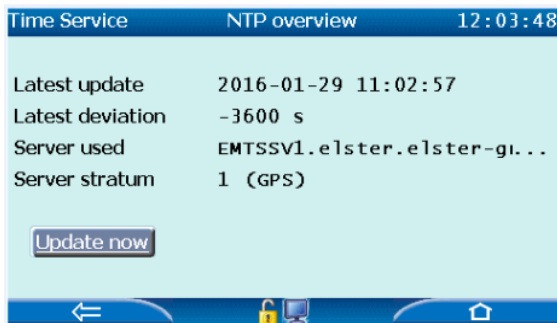

- Select here "**Update now**" to see the current values of the time information of the configured NTP-Server, regardless of the specified time intervals.

7.4 Announcement of events

7.4.1 LEDs over the interactive display



Check the LEDs. The color of these LEDs can be used to determine whether the measuring instrument is working properly or that a fault has occurred.

Above the interactive display, two multi-colored LEDs are placed: Left the Power-LED and right the Status-LED. In the "remote operation panel", the two LEDs are shown as a graphic illustration.

The power-LED

LED condition	Meaning
Off	Power off; no connection possible
Green, continuous light	Power on, connection possible

The status LED

LED condition	Meaning
Off	Power off; no connection possible
Green, flashing	Start-up phase after a power supply is switched on
Green, continuous light	There is no content in the error list. In analysis mode, the device is running error-free

A red or yellow status-LED indicates that there is a pending or non-accepted error. (The LED state is retained even after a restart and is displayed again). The status LED indicates the error condition as follows (in priority order):

LED condition	Meaning
Red, flashing	The error list contains at least one pending and unaccepted alarm.
Yellow, flashing	The error list contains at least one pending and unaccepted warning.
Red, continuous light	The error list contains at least one alarm that already is gone; it has not yet been accepted.
Yellow, continuous light	The error list contains at least one warning that already is gone; it has not yet been accepted.



Device problems: Elster GmbH offers services, troubleshooting assistance, and repair or replacements of non-functioning parts. Contact details are on page 3 of these Operating Instructions.

7.4.2 View event-related display texts in the error list

Background: If the status LED is red or yellow flashing or steady lights in these colors, records are in the error list. In this list, the device displays the event-related display-texts such as warning and alarm messages or system messages, such as reboot or power interruption. The error list is sorted chronologically; the most current message is displayed first. You can filter this list.

Procedure:	
You reach the error list main display via the icon  Error List . The error list shows all the current event-related display texts. Now you have two options:	
If there are only a few errors in the list, scroll down to specific messages.	To selectively filter messages from different parts of the software, select a filter from the drop-down list e.g. “Time Service” . It only displays the associated messages.

7.4.3 List of event-related display texts

The following section provides a selection of event-related display texts of the device.



Depending on the software version, the message text may differ from the examples shown here, although the meaning of the message did not change.

These are alarms, warnings, messages, or hints. All events are binary. They are available at a certain time or not.





The texts are produced by different software parts (called AFB and SFB). Depending on the content, the messages are deleted after eliminating the phenomenon caused or stored in the log or audit trail under the appropriate categories.













Depending on the parameterization of the device, some of the following warning and alarm messages occur.



In many cases, the message reason is mentioned in the message text itself e.g. **Lost archive entries**. For a list of all event-related display texts of the device, view the export window of enSuite. ⇒ See chapter 8 and the **online help**.















You can usually prevent or eliminate messages (warnings and alarms) of the time service SFB by changing the parameter settings. (⇒See chapter 8). If the parameterization has no errors, please contact the Elster GmbH.





Identifier	Root cause of time service SFB messages
 Alarm time setting	Following conditions are met: <ul style="list-style-type: none"> The system time differs strongly from the external clock. However, it is only the synchronization and not the setting of the system time that is permitted.
 Warning time setting	Following conditions are met: <ul style="list-style-type: none"> The system time should be set because the difference to the external time clock is too significant. It is nevertheless only the synchronization and not the setting of the system time that is permitted.
 Alarm or  warning External time source	Following conditions are met: <ul style="list-style-type: none"> External time sources are used and are marked as erroneous; a warning or an alarm is parameterized.
 Daylight saving: manually. Configuration invalid	Daylight saving (time change) is not done. The cause depends on the selected operating mode of daylight saving time. Please see chapter 7.3.9





Identifier	Root cause of system SFB messages
<ul style="list-style-type: none">  CRC alarm fiscal code  CRC warning fiscal code  CRC warning non-fiscal code  CRC alarm secured param.  CRC warning secured param.  CRC warning unsec. param. 	<p>When an "approval file" is used, the parameterization is monitored by the checksum (CRC).</p> <p>In case of deviations due to unauthorized modifications, the corresponding alarm or warning is triggered.</p>
 Battery low	In case of low battery capacity, please inform the Elster GmbH
 CPU load high	CPU load is high; please do not carry out additional functions like reading out archives.
 Power supply off	Power supply was switched off
 Power supply on	Power supply was switched on
 Restart by user / restart after run time error	The displayed reason has caused a restart / reboot
 System watchdog	. Shutdown was not error-free e.g. not all files are closed. Signal remains until accepted





Identifier	Root cause of user SFB messages
 Security switch open	Opening of security switch is reported
 User management Super administrator login Administrator profile login	Service or Elster personnel has logged in
 User profile X login	Customer profile has logged in (X = number 1-5 of the profile)

Identifier	Root cause of Q2 AFB messages
<ul style="list-style-type: none">  Operational calibration  Service calibration  Base calibration  Start-up  Verification 	<p>Notes on actions or situations that are currently being carried out or are pending. The analysis operation was exited.</p> <p>Rectification Messages disappears automatically as soon as the tasks are done and the device works again in analysis mode</p>
<ul style="list-style-type: none">  Operational calibration failed  Calibration successful 	<p>Results of actions</p> <p>Rectification Not necessary; the signal disappears automatically</p>

Identifier	Root cause of Q2 AFB messages
<ul style="list-style-type: none">  Process gas pressure alert 	<p>No sufficiently high pressure drop can be built up in the device; no valid measurement is possible.</p> <p>Rectification Check the inlet pressure and the flows of the device and place them in valid areas. If these are already within the valid ranges, please contact the Elster GmbH.</p>
<ul style="list-style-type: none">  Alarms XY min / XY max 	<p>An error event has occurred; the value specified in the message (placeholder XY) is outside the upper limit or outside the lower limit, e.g. raw values are erroneous or sensors are defective. It is also possible that the gas does not correspond to the specifications or a wrong parameterization is used. No valid measurement result is displayed. The final value cannot be calculated correctly.</p> <p>Rectification The parameterization sets the alarm limits; if you have made changes to the parameterization, you must undo them (⇒see chapter 8). If the message appears without changes, you should contact Elster GmbH.</p>
<ul style="list-style-type: none">  Alarm temperature time out 	<p>Sensor block does not reach its working temperature by error of heating or sensor and the Q2 will not start measurements.</p> <p>Rectification Please contact the Elster GmbH</p>
<ul style="list-style-type: none">  Alarm Operational calibration out of limit 	<p>If the operational calibration has not run error-free, the device will automatically return to the analysis state and use the old calibration values. Measurements are inaccurate.</p> <p>Rectification Make sure that all information regarding calibration in these Operating Instructions were followed and perform under these conditions a new automatic or manual calibration. If you do not succeed doing so, please contact the Elster GmbH</p>
<ul style="list-style-type: none">  Alarm Calibration gas pressure alert 	<p>If the operational calibration has not run error-free, the device will automatically return to the analysis state and use the old calibration values. Measurements are inaccurate.</p> <p>Rectification Make sure that all information regarding calibration in these Operating Instructions were followed and perform under these conditions a new automatic or manual calibration. If you do not succeed doing so, please contact the Elster GmbH</p>

Identifier	Root cause of Q2 AFB messages
 Alarm Master-slave parameterization error	An error event has occurred; the alarm boundaries (limits) are violated. No valid measurement result is displayed. The final value cannot be calculated correctly. Rectification Transfer a valid parameterization into the device and reboot it. If you do not succeed doing so, please contact the Elster GmbH
 Other master-slave alarms	As a rule, it typically involves subsequent errors resulting from other causes. Please contact the Elster GmbH
 Alarm Q2SENS communication timeout Alarm Q2SENS write error Q2SENS link lost Q2BASE link lost  Alarm signal Q2BASE write error	The adjacent alarms indicate communication and memory errors. Rectification Disconnect the power supply and reboot; repair by Elster service generally required. Please contact the Elster GmbH

Identifier	Root cause of Q2 AFB messages
 Warning Standard A failure	The final value cannot be calculated correctly. Rectification Please contact the Elster GmbH.
 Warning Standard B failure	
 Internal warning	The Basic System has a fault. The device does not operate smoothly. Rectification Please contact the Elster GmbH
 Internal alert	

Identifier	Root cause of archive AFB message
 Archive entries lost alarm  Archive entries lost warning  CRC archive alarm  CRC archive warning	The user archive system has a fault. Results could not been saved and archived in a safe manner. Rectification Please contact the Elster GmbH

Identifier	Root cause of Modbus AFB message
 Protocol error	The protocol has an error Rectification The message disappears automatically.

 **The user can also generate further display texts for each type. It is done in post processing AFB by changing the parameterization. For more information about parameterization and post processing AFB → see chapter 8**



7.4.4 Accept and removal of event-related display texts

The error list (see chapter 7.2.3) shows all alarms and warnings that are either currently pending or have already gone but have not yet been accepted. It is sorted chronologically; the most current message is displayed first. If more messages are contained than can be displayed at once, the message appears at the right edge of the scroll bar.

Acceptance procedure



Entries in the error list must be accepted (see the following steps). In the delivery state, this is only possible if the cause of the entry has been corrected. The acknowledgment behavior can be changed by enSuite. Please proceed as described in chapter 8.

Steps to accept clear error list	
1.	<ul style="list-style-type: none"> Navigate to the Error List Main display and open this list. (Activate: Home  -> Error List ).
(2).	To accept only messages of a certain piece of software from the list, open the filter drop-down list and use the corresponding entry in the list of Filter .
3.	Select Refresh to update the list which is held / fixed directly after opening. (Number behind = Number of new messages)
4.	Activate the action Accept all and the selected list will be acknowledged according to the configured acceptance procedure and updated.
(5).	If necessary, repeat these steps for additional display texts of other pieces of software



Errors can only be accepted and removed if this is consistent with the previously established acceptance procedure.

You may need appropriate rights. Details for the acceptance procedure are provided by the enSuite online help, (⇒see chapter 8)

After all messages have been accepted, the system is again in an error-free state and the status LED will light green. From the display of the error list, you can jump directly to the log display with the hyperlink **Logbook**. The log also logs on coming and going of all messages (alarms and warnings). It has archive character. Each entry is assigned an order number. The entries removed from the error list can be found here.

7.4.5 Other possible error events during normal operation (troubleshooting)

To assist in the troubleshooting and to resolve problems, this chapter provides guidelines for troubleshooting. The cause of these errors can be located by controlling the input and sensor values and, if possible, by removing them.

Steps Troubleshooting	
1.	Check if the process gas has the correct pressure
2.	Check if the calibration gas has the correct pressure
3.	Check that the vent line / exhaust tube is not clogged
4.	Check the set point of the needle valves in the device
5.	Check whether the supply voltage is available at a sufficient level
6.	Check the communication connections
7.	Check the list in the display " Sensor values " for red entries (Display of "Sensor Values" see chapter 7.2.4)

The following are measures against some errors. Always observe all safety regulations when troubleshooting, in particular:

The analysis part may only be opened by Elster authorized personnel!
La partie de l'analyse ne peut être ouverte que par le personnel autorisé d'Elster!

You need written permission from the station operator.
Vous avez besoin d'une autorisation écrite des opérateurs de station.

Use only explosion-proof, approved work equipment.
N'utilisez que l'équipement antidéflagration approuvé.

Do not open the connection box until all safety precautions have been observed.
N'ouvrez pas le boîtier de connexion avant de vous être assuré de respecter toutes les mesures de sécurité.

Electrical entries must not dissolve in an explosive atmosphere!
Les entrées de câble ne doivent pas se dissoudre dans un environnement explosif!



Loosen or removing the breathing element is forbidden!
Le relâchement ou le dévissage du reniflard' est interdit

Work only when Q2 de-energized and has no pressure. There must be no explosive gas atmosphere.
Ne travaillez que lorsque le Q2 est hors tension et dépressurisé. Il ne doit pas y avoir de gaz explosif dans l'air.

Protect all open lines and ports from dirt.
Protéger tous les câbles et tous les ports ouverts de la saleté.

Before switching on the unit again, ensure that all gas connections are sealed and that the grounding or protective conductor is properly installed.
Avant de rallumer l'appareil, assurez-vous que toutes les entrées de gaz sont scellés et que le câble de mise a la terre est bien installé.

Correct the interference at point 1 - 4 (gas supply failure)

The following measures can be taken if a fault occurs in the gas supply, e.g. abnormal calibration gas loss.

Steps to resolve gas supply disruption	
1.	Perform a leak test by examining the entire gas passage (from the cylinder / from the pipe / to the device) with a gas detector
2.	Seal leaks found in a professional manner.
3.	Set the regulators and valves to the required values
4.	Disconnect plugged lines from the power less device. Blow the line with non-combustible gas and eliminate blockages and deposits. Make sure not to exceed the maximum pressure

Correct the interference at point 5 (electric utilities and insulation failure)

The following measures can be taken if a fault in the electrical energy supply occurs. To localize the fault, the use of a voltmeter is required. If the device is not powered or the supply voltage / supply current is too low, you may see following effects:

The interactive display and the LEDs are dark

The interactive display is dark and the right status LED is off or flashing

Steps to test the electrical supply	
1.	Check all switching and safety devices outside Q2 and replace defective fuses.
2.	Check if the cable connections between the device and the electrical supply are OK (no disconnection in the wiring). Make sure again that there is low resistance of the electrical contact. If necessary, connect the cables again.
3.	Make sure that there is power to the voltage at the feed source and that this is not affected by congestion of other devices, insulation failure or defective components and therefore is reduced. Remove or replace these parts if necessary.
4.	Measure the open circuit voltage (without connections). If a defect is present replace or repair the electrical supply.
5.	Measure the incoming open-circuit voltage of the power cable to the device. Switch off the electrical power and disconnect the plug of the supply cable at connection board in the Q2 connection box. Switch on electrical supply and execute a voltage measurement in the plug. If the voltage is missing or significantly less than the open circuit voltage, replace the cable (power less) from the power supply.
6.	If the problem is still not resolved after 1 -5 steps, the fault lies in the interior of the device. Please contact the Elster GmbH to check the internal fuse. For replacement it is necessary to open the housing; this should be performed for safety reasons only by the service or appropriately trained staff.



If the overheat protection circuit or the internal fuse has triggered, the interactive screen is also dark and the status LEDs are off. The components involved in the measurement are switched off. Please contact the Elster GmbH.

Correct the interference at point 6 (communication error)

The following measures can be taken if an error occurs in data communications.

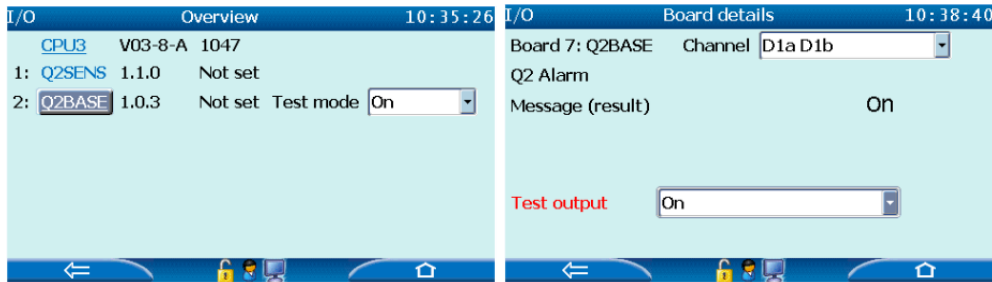

If there are several devices on the bus, focus on the slowest participant when selecting the operating mode! If the bus communication is not working, the device might be configured in a wrong operating mode.

Steps to check the communication	
1.	If changes have been made to the parameter settings, you must undo them, ⇒ see chapter 8.3.5
2.	Check the communication cables for damages. Check each cable for "terminal to terminal" connection
3.	Test the function of the digital outputs in the disconnected device. Check with a measuring device, whether there is a connection between the switching signal line and the return line. There must be no connections. Exception: Output DO_1, the opener.
4.	<p>Navigate to display I/O Overview. Select "On" for the test mode of the corresponding hyperlink (in the example Q2Base). Activate the hyperlink to switch to display I/O Board details. (Requirements: I/O parameterization is available; device is ready for use)</p>  <p style="text-align: center;">Figure 7.61: Display I/O overview and board details</p>
5.	<p>Check the function of the digital outputs during operation. Select the output to be checked under "Channel" in display I/O Board details. The display shows the target state of the output next to the message (result). In the example, "ON". Next, check with a meter the displayed result. Repeat the procedure with "message (result)" "Off". If the measured results like the displayed results, there is no error.</p> <p>Behind "Test output", you can change the states of the output independently from the real conditions. Measure each parameterized output in both states (on / off) to get a complete overview of the error situation. Do not forget to switch off the test mode!</p>

Correct the interference at point 7 (sensor error)

Steps to check sensors	
1.	If there entries in red thedisplay " sensor values ", the sensor that detected this value is outside the valid range. This is a defect you cannot remedy by yourself. Please inform the Elster GmbH



If you have no success with above methods, please contact the Elster GmbH. Contact details are on page 3 of these Operating Instructions.

8 Operation and parameter setting on the PC with enSuite

In addition to operating the Q2 device on the interactive device display (locally) or on its simulation, the remote operation panel, you have the option of using a computer via the PC software **enSuite** to get access on the device and perform parameterization and diagnostics. This PC software supports the GasLab Q2 and other devices from Elster.

enSuite is also used to check the parameters and device settings or to log data and thus to gain an overview. Subsequently, the software concept and ensuite is briefly described as well on how to install the software. Further details of the software can be found directly in the ensuite online help. Also note the other information in this chapter before you work on Q2 via the PC.



Always work with the current version of enSuite from the download area (see next page). To access all versions of the device:

8.1 PC-Software concept of GasLab Q2

Q2 based on an Elster product platform, called **encore**. All new designed measurement devices are based on the same hardware components and software concepts. Both the hardware and software of the devices have a modular design.

The software modules are made for one of the basic functions, such as the I/O connection or the connection of digital protocol interfaces provided from the Basic System with its SFB (abbreviation for **S**ystem **F**unction **B**lock). On the other hand, they consist of the application-specific functionalities provided from various AFBs (abbreviation for **A**pplication **F**unction **B**lock).

Because of this modular design principle, each device can be optimally adapted to individual requirements. The following figure shows this design.

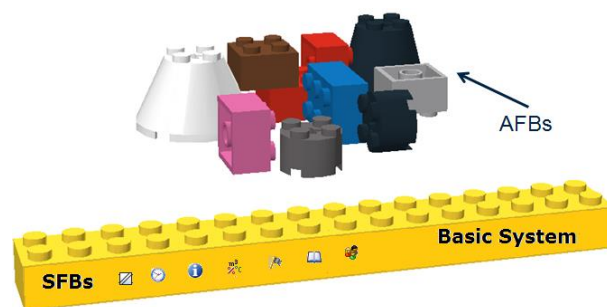

Basic system with (SFBs) and (AFBs)

Figure 8.1: Bricks /enSuite

The device software of each product consists of the following:

- The basic system that contains different basic functionalities (SFBs) and
- a number of application-specific functionalities (AFBs). An ever existing AFB for the device-specific characteristics has the same name as the device, in this case Q2.

8.1.1 Installation and start of enSuite

If you differ from the factory parameterization, you should change the parameterization before or during commissioning. This software helps you to fulfill the work. An example of such deviations is the use of no stored gas properties in the verification operation calibration or service calibration of the device. You can download the installation program file from the Elster Instromet website in the section **Software downloads**:

www.elster-instromet.com/en/software-downloads



On this page, you find a file with the individual steps of the installation and the minimum system requirements. Perform the installation according to these hints. Please monitor screen messages during the installation.



After the installation, rebooting is not required, and the following link icon appears on your desktop.



For the non-fiscal operating, the PC software enSuite also allows communication via network interface with the Modbus TCP protocol.

Start enSuite either via the enSuite program symbol on the desktop or via the start menu (Elster group of programs). After opening, the interface of the software enSuite appears. At the top the menu bar appears and the button bar is displayed below.

The rest of the program screen is divided in window panes. Communication is established via this input and output windows.

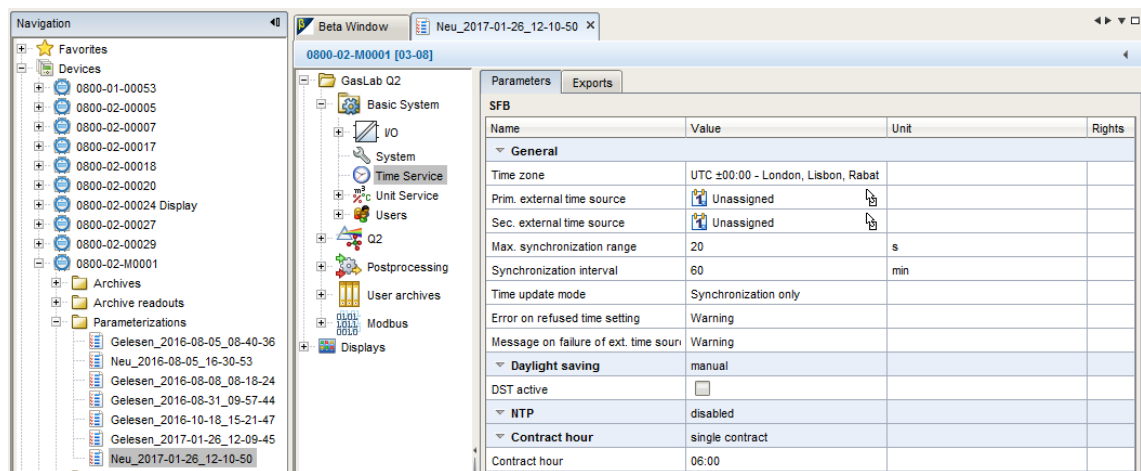



Figure 8.2: Example: navigation window and parameterization window.



More information is available in the online help that you can activate with the [F1]- key. Or click on  the menu bar on Help. If not already open, the general online help window appears.

enSuite remembers the position of the window of previous applications. With the function "Reset Window"  (see the menu bar below "Window"), the original state can be restored



Please use the online help to get an overview of the enSuite basic functions. Among other things, you will find information by setting the inactivity timeout or automatic logout.

The other sections of the chapter deepen and supplement this information and are easier to understand with this background knowledge.

8.1.2 Connection and disconnection with devices



The individual devices are identified in the enSuite database via their serial numbers. In addition, it is possible to append an individual name to the serial number (highlight device, select properties in the context menu and enter the name).



The connection to one or more devices and subsequent disconnection can be done in various ways, for example, with the following symbols.  Connected devices are signed with a green dot in the symbol preceding the serial number.

In the **online help** of enSuite, you will find all the steps of the device connection and disconnection explained in detail. Follow these instructions and remember the following hints in addition:



Use only the TCP / IP data connection. The network interface is found on the top of the device in the connection box. You cannot use the USB connection because it is not accessible in GasLab Q2.



For the initial connection with enSuite, you need the network basic settings of Q2. These can be found on the Ethernet I/F display on the device. You can reach this display with  (Home),  (System),  (I/O) and activating CPU 3.



For proper TCP/IP connection, both the PC and the device must be connected to the same network, and, if necessary, the IP addresses must be customized.



If you are changing the network settings of a device that was already connected via your enSuite application, you will be asked to save these new settings when reconnecting. Then click on yes.

If the connection could not be made, an error message appears. This error may have several causes, such as the device is turned off or is still in the startup phase. The address you entered was incorrect or a hardware errors occurred. ⇒ See chapter 7.4.5

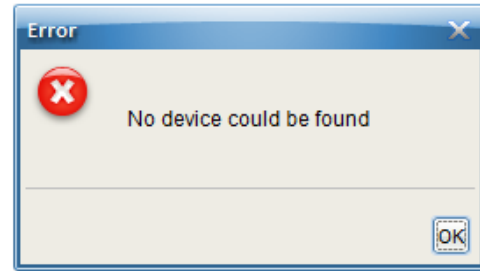

Figure 8.3: No connection was established

A scheduled automatic disconnection takes place upon recording a new parameterization. See chapter 8.3.

The connection can also be interrupted by other events such as "supply voltage failure" in the device or a cable break. In these cases, the disconnection is displayed in a dialog box.

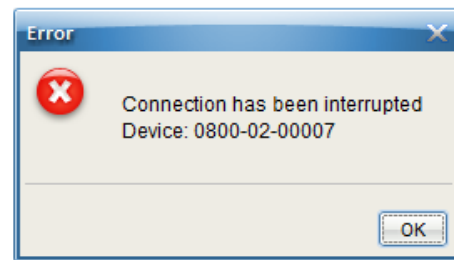

Figure 8.4: Connection has been interrupted

8.1.3 Readout and watch parameterization (device settings)



Read the parameterization out after each change.

Save each readout as a backup for emergencies separately. There is no automatic safe function of the parameterization in enSuite.

There must be an active data connection to the device (see 8.1.2) before the parameterization can be readout from the Q2. You do not need a login for the readout. When connected select the action "**Read out parameterization**" in the lower section of the navigation window or open the context menu and select "**Read out parameterization**"

Enter a name for the file in the **save as** dialog.

Next, the read parameterization is stored with this name. In the branch under **Devices - <Serial number/Name> - Parameterizations**.

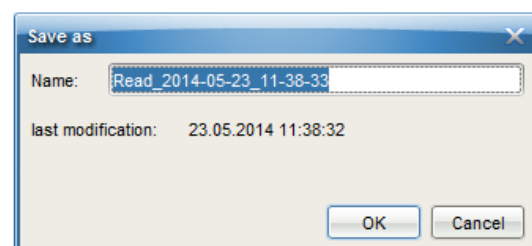

Figure 8.5: Dialog "Save as"

Change the proposed name e.g. to "backup_YYYY-MM-DD". Using a date always allows you to allocate the correct backup).

Check the storage in the navigation window, a file with the same name must exist now

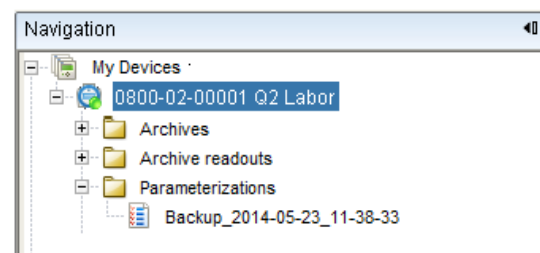

Figure 8.6: Example saved parameterization

Certain parameters are set to default values by the manufacturer. You have now backed up these values. Make no other changes in this data file; it can be used in an emergency case for restore and backup purposes.



Changes to parameterizations already saved in enSuite are stored under the old name. The original file is overwritten! Always read out the current parameters from the Q2 for any changes. Do not use parameterizations stored for documentation or backup as you will lose the content in the event of changes.

Les modifications apportées aux paramètres sont déjà stockées dans enSuite sous l'ancien nom. Le fichier original sera écrasé! Passez toujours en revue les paramètres actuels du Q2 pour voir les changements qui y ont été apportés. Ne tenez pas compte des paramètres archivés ni des paramètres de rechange, car vous perdrez le contenu en cas de changement.

After a double click on the file, enSuite opens the parameterization window and shows the device parameterization. The **online help** provides more information about this window.

8.1.4 Watch factory parameterization of the SFBs and AFBs

In order to determine with which SFBs, AFBs, and settings the device was delivered, readout from the unchanged parameterization as described in the previous chapters and view the tree structure in the parameterization window.

This view displays on the left side the use of the above-mentioned "enSuite modular design principle" in the delivery state of the device. These folders and subfolders contain the factory-set parameters, as long as you have not made any changes. The individual parameters are displayed on the right side of the window after selecting the block.

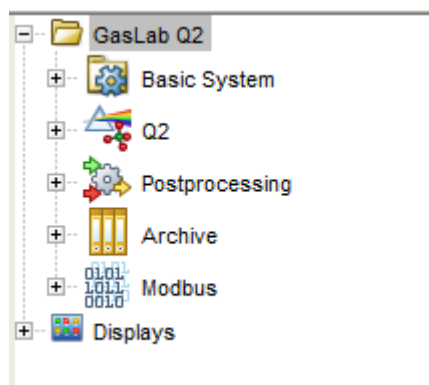

Figure 8.7: Example device tree structure

In general:



Factory parameterization is shown if you read the delivered parameterization in the "parameterization window". The meaning of the parameters is explained in details in the online help.

The following part provides a brief description of the SFBs and AFBs:

Basic system (SFBs)



includes basic functions such as time service, user management or I/O functions. Also note the software concept at the beginning of this chapter and the online help.

Q2 AFB



includes the default parameters, which are explained in the online help. Here you can get information on: calculation standards; correction input; base calibration; service calibration; operational calibration; verification and limits. Flushing times and the composition of the calibration gases are there also stored and set.

The AFBs **Post processing**, **Archive** and **Modbus** are used for calculations archives, and data communications. The final parameterization is not determined at delivery. These AFBs could subsequently be configured and designed for the necessary functions. The **online help** contains the necessary information.

Displays



the folder contains all displays (see "Home" chapter 7). All factory displays are protected. You realize that on the "padlocks". You only have the option to customize the displays and create new displays. See the following information in these Operating Instructions.

8.2 User management and login

Six different user profiles with different rights are available in user management. The operator is provided 5 profiles. The other profile (Administration) is used for service, production, and development purposes; it is not accessible during normal operation.

The authorization concept is based on role-based access control. The rights are assigned to each profile. Each profile contains a non-erasable super-user "SUX" and offers the possibility to create up to 9 additional users.

Thus, the user has access to the relevant part of the parameters.



In principle, a parameter can only be altered and used in the device, if the user has the authorization and if the position of the SSW switch permits it.

In the case of rare work, without existing authorization, you can get a so-called "daily" (password for a day) from the Elster GmbH to carry out this work by arrangement.

Changes in the user management are not possible with the given passwords. If you want to change this presetting or use the hardware security switch (SSW), please contact the Elster GmbH.

The login dialog appears automatically at the appropriate point in the action.

To login, you need the **User name** and the **Password**.



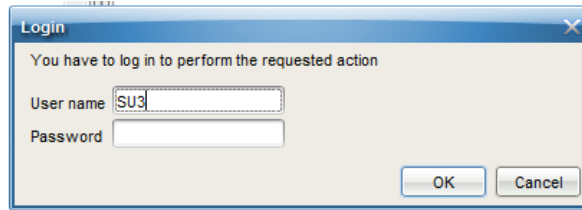

Please ask the station operator or the super user.



In the delivery state, the default login e.g. as user SU3 without a password is preset. Further information about the user management, see the description of the Basic System in online help.

8.2.1 View access rights

Requirement: The parameterization is shown in the parameterization window of enSuite. The corresponding parameters are displayed in the tab “parameters” on the right side of the parameterization window. Rights are managed by means of symbols per user profile. Wherever rights are assigned, a toolbar is displayed in the **rights** column. The toolbar consists of two parts:

- Button 1 to 5 rights for user profiles 1 to 5:  each button is assigned an unique icon. The order corresponds to the position of the profiles in the user management. As soon as a symbol is activated, the corresponding profile has the corresponding right. There is no icon for the administrator profile.
- Button 6 and 7: fiscal security settings  Button 6 is the icon for the protection by the security switch (SSW) icon  and button 7  the icon for the fiscal audit trail. It is only displayed on the parameter level. Once a symbol is enabled, this security setting is applied.



If the authorization is not available, these buttons cannot be selected or permanently changed. In this case, they are only used as advertisements.

8.2.2 Restriction on Q2 relevant parameters (use virtual login)

A parameterization is transferred to the device and possibly rejected at the end of the transmission. The device checks the requirements and authorizations only before using. Therefore it is possible to change parameters beforehand in an unauthorized manner. To prevent this,, you can filter the parameter lists beforehand using the function “**use virtual login**”

Precondition: You have selected the offline parameterization (see chapter 8.3) The required parameterization is opened and the top folder is selected. In the right part of the window you see the options shown below

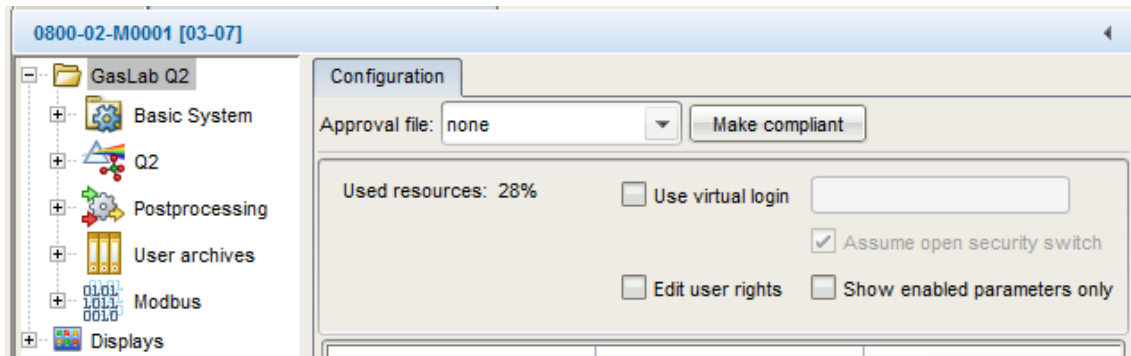

Figure 8.8: Function “use virtual login”

Activate the online help in enSuite to learn more about the required settings. The following figures in these Operating Instructions usually go by the use of this function under the name "su3".

Example: If you use the virtual login function as **SU3** and select the **KMF Live** page, you will get the following information:

No parameters are available here.

In order to view all parameters regardless of their access rights, clear the check box **use virtual login**. The page displays now the existing parameters.

Exports		
KMF Live		
Name	Unit	Rights
▼ Abs1s		
# Tave		
# Tlok		
# Alpha		
# Value		
# Filtered value		

This page contains only internally used values and will not be further explained. If you make changes here, the device rejects the parameterization after the transfer.

8.3 Change existing device settings (parameterization)

In the enSuite database, different types of parameterization are possible. They are described in greater detail in the online help. This Operating Instructions only refers to the adjustment of the preset factory settings.



Upon delivery, a factory parameterization (device parameterization) is always present. If necessary, it only needs to be customized.



If you deviate from the factory settings, please note that you must always be logged in for your changes or their transfer to the device and remember the following:

Only parameter changes that the logged-in user is permitted to execute may be applied. Non-editable parameters are listed in gray in the parameter lists and are labeled with the symbol  or are not shown depending on login type.



Display (see parameterization window left part below)

If you have the necessary rights to use the display editor, you can modify device displays. This documentation describes the structure of the displays in the delivery state. Since the change of display is not provided, this shall not be discussed in these Operating Instructions.

Furthermore, a distinction is made between **offline parameterization** and **online parameterization**. These terms and the differences are also explained in the online help and are taken up below.

8.3.1 Change device parameterization offline (offline parameterization)

Requirement: The parameter file was read as described in chapter 8.1.3 and is opened in the navigation window by double-clicking. The parameterization window is displayed. The online help provides more information about this window.



Do not use parameterizations for archiving or backup purpose to make changes because you will lose the original content. Instead, always readout a parameterization for changing purposes according to chapter 8.1.3.

Ne pas utiliser les paramètres à des fins d'archivage ou de stockage pour faire des changements, car vous perdrez le contenu original. Au lieu de cela, lisez toujours les paramètres conformément au chap. 8.1.3 de.

This parameterization is done in the following steps:

1.	Modify and save the existing device parameterization. 
2.	Transfer changed parameterization in the device



All parameters to be processed are subject to the restrictions of the user management and can be changed only with appropriate authorization and position of the SSW (security switch).

The parameterization is edited in the parameterization window (see following figures) of enSuite. The **online help** provides details about this window.

On the left side of the parameterization window, the software components are displayed. After selecting and unfolding of a block, the corresponding parameters are displayed in the tab "parameters" on the right side of the parameterization window.

Depending on the situation, the values of parameters can be freely changed, or there is a selection list with the appropriate options. Similarly, some functions are switched on and off by using a check box. See the following examples:

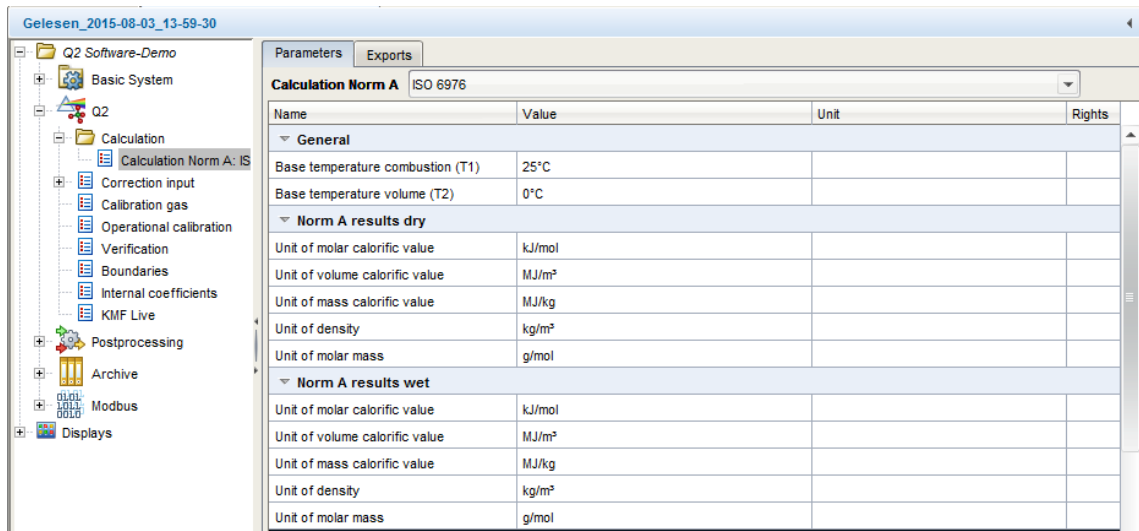

Figure 8.9: Example left and right part of the parameterization window

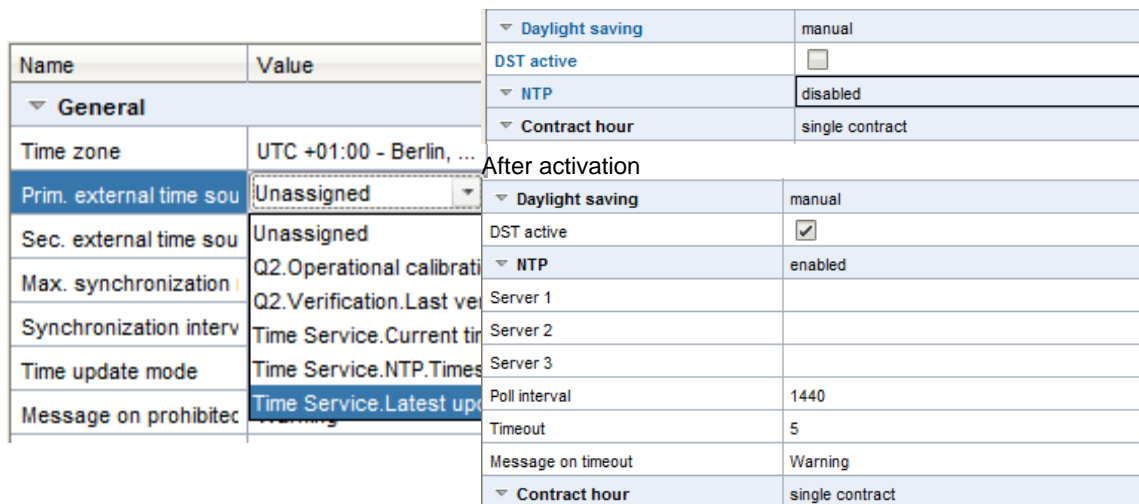



Figure 8.10: Example selections and reactions of the parameterization window

 **New functions or changed operating modes require additional parameters, which are then made available for editing in a new subordinate branch. Any such structural changes to a parameterization are only possible using offline parameterization.**

There are different types of parameters. Some can be switched. Some are displayed in separate windows, for example, export values.

Export values are required, for example, because the function groups of the device provide values for each other via the parameterization.

It must be ensured in each processed parameterization, that the relevant references are correct.

Parameters			
Output channels			
Name	Value	Unit	Rights
D1a D1b	Unused		
D2+ D2-	Unused		
D3+ D3-	Unused		
D4+ D4-	Message output		
I1+ I-	Pulse output		
	Trigger output		

Figure 8.11: Example parameter can be switched

Parameters			
Exports			
Time Service			
Name	Unit	Rights	
General			
# Current year			
# Current month			
# Current day			

Figure 8.12: Example: export values in the parameter window



The possibility of switching the parameter type depends on the respective parameter. For more information about types, units, and windows of parameters, see online help.

During editing, the program uses colored markers to indicate the status. If the parameter label is blue, this means that the parameter was edited but the change has not yet been saved. Any superordinate branches are also blue at the same time. A red parameter label indicates that changes have been made and the parameterization is not yet valid. The parameterization can be saved, but it can't be transferred to a device.

Name	Value
Device control limits	changed
Start delay	but not been saved.
Name	Value
General	changed
Password	but not valid
Sensor limits	no unsaved changes
UIR1 upper alarm limit	and valid

Figure 8.13: Example parameters during editing



If you delete a parameter setting, an input value or change it fundamentally, which is used in another context, all the links are not valid for this value and are automatically deleted from the parameterization program. You will receive a message on this deletion so that it is obvious which links must be recreated.

If you have finished making changes, save the parameterization . After successful storage, the disk icon will be grayed out and the displayed lines are in black color. Now you can transfer the valid and stored device parameterization to the device, with the matching serial number.



Working steps for transferring parameterization to device	
1.	Establish a data connection to the appropriate device. (⇒See chapter 8.1.2)
2.	Highlight the desired device parameterization in the data structure of the navigation window
3.	Select the action Transfer parameterization to device (e.g. at the context menu)
4.	Subscribe to the appearing login dialog

The parameterization is transferred. If the new device parameterization is likely to bring about changes to such parameters, which are protected by the security switch (SSW), but the security switch is closed, then the message “**Device could not be parameterized**” appears following the transfer. The device does not reboot, the old parameterization is still used.

If the parameters are not under the protection of the security switch or if they are open, the transfer is done and the device reboots. With the reboot, the connections to the remote operation panel and to enSuite are disconnected and an automatic logout is performed. The device now operates with the transferred settings. These remain in use even after the device is switched off and on.

8.3.2 Edit device parameterization in a connected device (online-parameterization)

This method, also described in the online help, can be used for small changes. This requires a data connection to the device. (⇒See chapter 8.1.2)

Working steps for changing device parameterization in the connected device online	
1.	Highlight the device in question in the navigation window, either under the devices branch or under the connections branch.
2.	Select the entry parameterize online in the lower section of the navigation window.
3.	Login with your “user name” and “password” using the “login dialog” that appears.
4.	The parameterization is read; the parameterization window then opens up for editing purposes (elements of parameter tree are shown in black)
5.	Make the changes. After you enter the changed value, changed parts of the parameter tree are displayed in green color. (A parameter label highlighted in green indicates that the parameter was edited but the change has not yet been transferred to the device.)
6.	Activate the Transfer parameterization to the device button  . (Once the transfer is completed, the parameter label is then blue . This indicates that the transfer was completed but the edited parameterization has not yet been saved in enSuite.)
7.	You can and should save  the edited parameterization in enSuite in order to back up the current status. (After saving the values are displayed again in black.)

Then click on the top folder in the parameter tree, select the tab as shown opposite and adapt your login status for other tasks or log out.

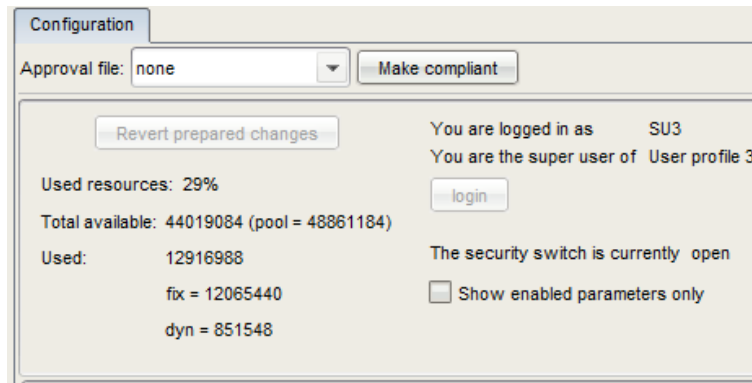

8.3.3 Immutable preferences

The “**user and rights management**” of enCore devices makes it possible to define in a very detailed manner the changes that users are allowed to make. Any changes raise the risk of incorrect setting of the device. To reduce this risk, you have no right to do actions that are not needed in normal operation.



Some settings cannot be changed by the user due to his lack of suitable user rights. These includes:

AFB configuration, operating and fiscal software and approval files.

If you do not want to accept these default settings, please contact Elster GmbH

You see these forbidden actions under the tab. “**Special user rights**”, which you can find in the **Basic system** under **User SFB**.

8.3.4 Change automatic operational calibration

To ensure measurement accuracy, Q2 is calibrated with a base calibration in the factory prior to delivery and further checked and corrected during operation. This is ensured by the automatic operational calibration once a week and an annual service calibration.



With the factory settings and the settings in place during commissioning, the operational calibration runs without additional intervention automatically. “Calibration” appears on the first row of display during this operation. It takes a few minutes.

A requirement for automatic operational calibration is that the operational calibration gas (mixture of methane + CO₂) is permanently connected to the device and is present at sufficient pressure. The calibration starts with a flushing time of the calibration gas (step: flushing), which ensures that the device is only filled with calibration gas. After completing the operational calibration, the device automatically switches back to the process gas and continues (after process gas flushing) with the measurement.



During commissioning, the flushing times and components of the calibration gas must be adapted.

Pendant la mise en service, les temps de purge et les composantes de la calibration du gaz doivent être ajustés.

Most operating scenarios are met with the factory settings. Nevertheless, it may be necessary to customize some parameters. For example, the exact composition of the calibration gas mixture must be checked with enSuite (or on the device) according to manufacturer's certificate of analysis and, if necessary, modified. Similarly, the preset flushing times must be adapted to local conditions. Change the settings with the guidance in the enSuite online help and chapter 7.3.5. The device also offers other possibilities to modify the automatic operational calibration, e.g. change the day and time of the calibration. To do this, change the parameters with enSuite, according to the instructions in the online help.

 **Changing the time-controlled trigger (interval, day, time) of factory settings e.g. the measurement is done using two redundant devices, otherwise during calibration both devices do not get new measurement results. It may be useful to start an automatic operational calibration at certain events e.g. after a reboot or when an input signal is triggered.**

 **If the calibration fails, an error message prompts the user to initiate an action, for example, new base calibration or repair, if necessary. The parameters of the last successful calibration remain in use. If you cannot resolve this error, please contact the Elster GmbH.**
Tip: changes in enSuite can be done more easily than in the on site. To start operational calibration manually, proceed as described in chapter 7.3.3 . More information about service calibration, see chapter 9.

8.3.5 Reset all parameters to default condition

If the device does not achieve acceptable results, e.g. by several incorrect settings, it may be necessary to restore an older parameter setting or the default condition.

 **This procedure should only be used in emergency situations when all other options have been exhausted. The current device data will be deleted. // Cette méthode ne doit être utilisée que dans les situations d'urgence lorsque toutes les autres options ont été épuisées. Les données actuelles supprimés de l'appareil.**
When in doubt, contact the Elster GmbH. // En cas de doute, communiquez avec Elster GmbH
Be sure to save all previously required data on an independent external disk or computer. // Assurez-vous d'enregistrer toutes les données nécessaires sur un support de données externe ou sur un ordinateur indépendant.
A backup according to chapter 8.1.3 must be available. // Un enregistrement de rechange au chapitre 8.1.3 doit être disponible.

Working steps to restore default setting in the device	
1.	Start the program enSuite
2.	Back up all relevant data of the devices on an external disc or computer
3.	Install the „backup parameterization“ created according to chapter 8.1.3 on your PC
4.	Connect with the device.
5.	Transfer the default parameterization in the device.
6.	The device will reboot and is now working with the factory settings.

8.4 EnSuite during service operation

8.4.1 Customize displays

In normal cases, there is no need to edit or customize the displays. But if you have the permission, you can do the following (navigate to the display enSuite page):

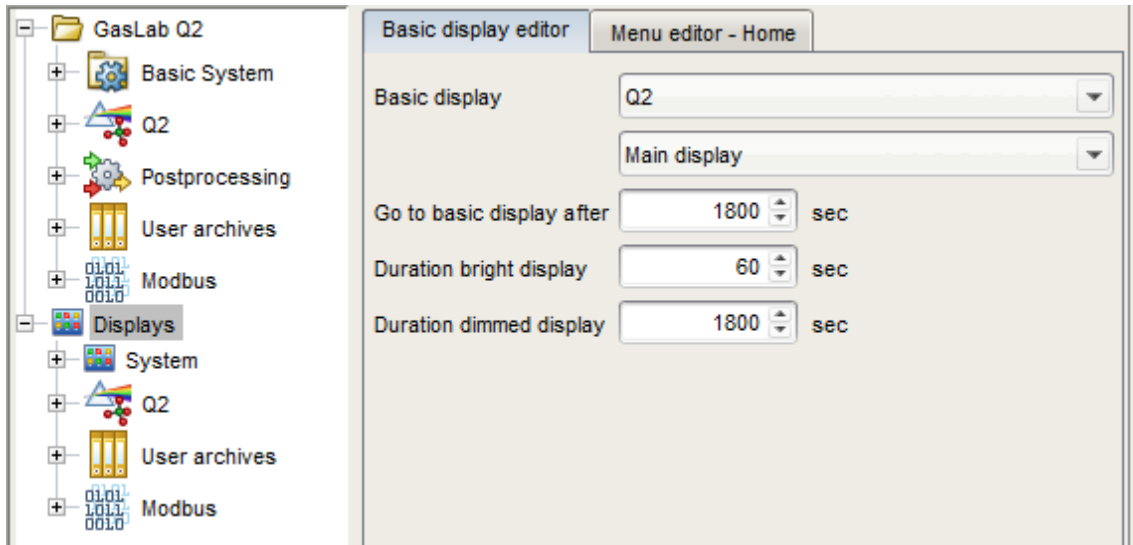

Figure 8.14: Basic display editor

On the right side of the parameterization window, various settings and options are offered under tab **basic display editor**

- **Basic display -**
With the two selection menus, you can specify which display / sub display is the device's first display when you log in or reboot.
Use the first selection menu to set the AFB.
The second menu is used to select sub displays if present.
- **Next, go to basic display.**
Here you can set the current display exit time, and the basic display is shown again. Do not choose a time that is too short, because after a break in operation, the previous display has to be called again after the specified time, which makes the work more difficult.
- **Duration bright display -**
if a bright display is not used for an extended period of time, it is darkened. Here, you can set the time until the darkening occurs.
- **Duration dimmed display -**
if a darkened display is not used for a long time, the screen is switched off. Set the time after this switch-off occurs.

The device displays are also listed on the right-hand side of the parameterization window on the tab **Menu Editor - Home**. If there is an existing authorization, you can change various settings using the context menu and the icons on the right side.

8.4.2 Update date and time with enSuite

Requirement: The user has the right to update device time (⇒see chapter 8.2.1) and an active data connection to the Q2 device exist. (⇒See chapter 8.1.2).

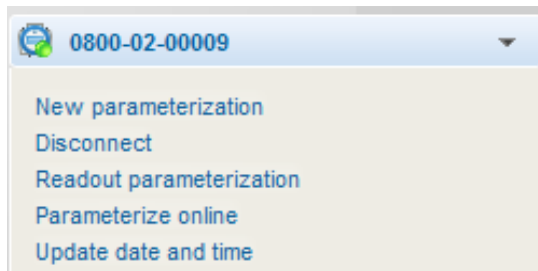

- ▶ Click in the bottom of the navigation window on the action “**Update date and time**”, and login (dialog will be displayed). Select the appropriate setting from the presets and confirm with the bottom button.

Figure 8.15:

Navigation window **Update date and time**

The settings are immediately accepted by the device. If the date and time could not be set successfully, enSuite displays in the **output window** a warning and an error message. The parameterization itself has not changed with this action.

If the **output window** is not displayed in enSuite, you can open it in the menu bar under **Window - output** or use the **<Ctrl + 4>** key combination.

8.4.3 Set time-related values and actions in the Time Service SFB

Apart from the date and time, you can set any other time-related values and timed actions in the **Time Service SFB** as device parameterization. The online help provides information about the necessary parameters to adapt.



The system time can be matched against (highly) accurate time servers via the network of the Q2 via the Network Time Protocol (NTP). Activate this parameter and proceed as described in the online help to use this function.

In the export value window, the SFB provides timed events of the type signal  under **Basic System - Time Service - time events**. Q2 generates these events on the basis of the system time and the (parameterized) day start. They can be used as input signals for time-controlled actions in other SFBs or AFBs



For more information about the using and setting of time controlled actions or time events, see the Time Service SFB in online help.

8.4.4 User profile management

The main user of the profile has the right to manage the other users of the profile, he can add new users, modify existing ones, or change user names. To do this, the required parameterization is opened offline and the user profile in branch  **users - user management** is selected.

On the **User list** tab, all users are listed. In the Profile name field, you can enter a meaningful name for the user profile, for example, company, or location. This name is used in the folder name of user management.



The remaining steps for creating and deleting users are specified in the online help. Press F1 to access it

To change the name of a user, select the desired name in the list and click on the dialog **Edit user** will be displayed. Enter a permissible change in the dialog box, note the tip in the dialog. As soon as your input is allowed, enSuite will activate the [OK] button, and you can close your change by clicking on it. The old password is deleted as indicated in the warning. The changed user is stored with an empty password in the parameterization.

Before input

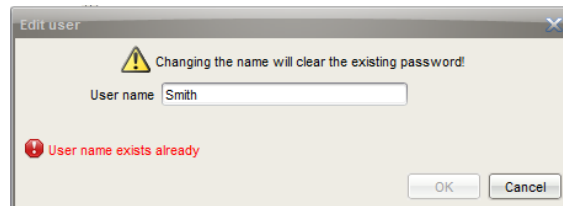

After input

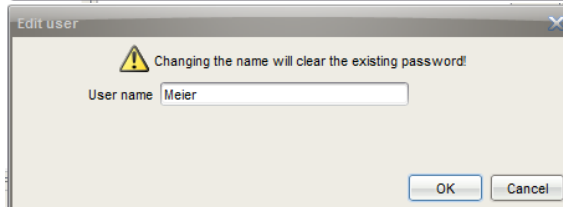

Figure 8.16: Edit user dialog

Save your changes to the parameterization and transfer the changed parameterization in the device. Then the user can login and perform actions with these rights.



There is no default password assigned, also a newly created user has no password. You should now implement a (starting) password. You can use the online parameterization (see notes below) or the interactive display according to chapter 7.3.6.

Password is assigned with the online parameterization

Connect with the Q2 and select "**online parameterization**". A login dialog appears. Login as super user SU3. Click "**OK**". The parameterization is readout. Open in the basic system branch **users** **user management** and select the appropriate user. By double clicking on the user you want to assign the password, and the following dialog opens:

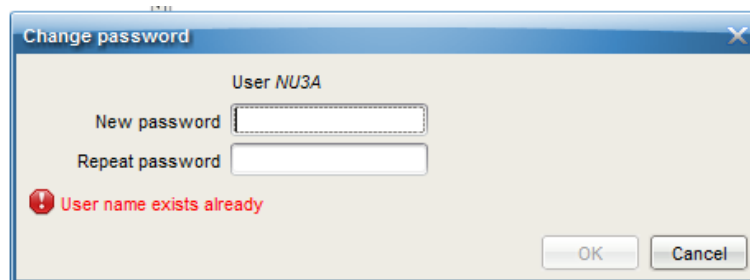

Figure 8.17: Change password dialog

Enter a valid password in both fields in the dialog box, note the notes in the dialog. As soon as your input is allowed, enSuite will activate the [OK] button, and you can close your change by clicking on it.

The new password is activated now. After selecting OK, you can disconnect. If necessary, the user can change his / her own password on the device or remote operation control panel. See chapter 7.3.6.

8.4.5 Functions “Read out archives” and “Show archive”

All relevant data can be logged in archives. In addition to the three permanently available archives "**Audit trail (system)**", "**Audit trail (fiscal)**" and "**Logbook**", further archives may be created on the parameterization in the archive AFB. The data can be readout via enSuite to save the content or to secure it.

Archives / logbooks can also be viewed on the device. Each entry can be displayed in English and device-specific language (national language).

 **The fiscal audit trail is only filled if the SSW is closed and an approval file is used, which provides.**

Emptying / deleting the archives is only possible with corresponding rights and an open SSW.

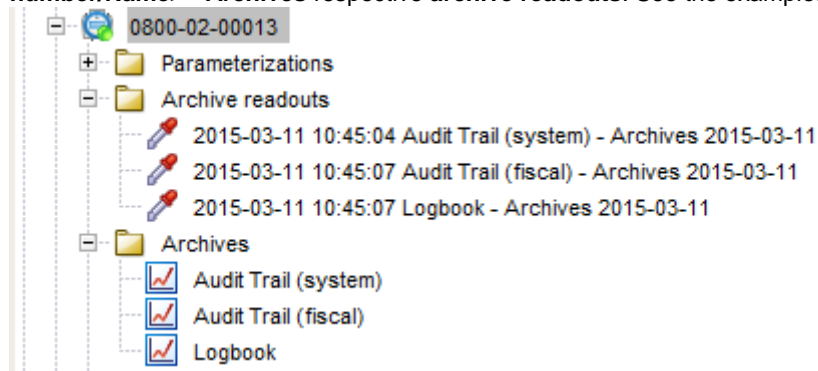
Working steps to read archives	
1.	Make a connection to the device (⇒See chapter 8.1.2) and select in the bottom part of the Navigation Window, the action "readout archives". You will see a dialog box, in which the archive query can be configured.
2.	Choose the archives and settings you need in the dialog. Change if necessary the proposed label for read out (always accept the date to get a time allocation). After selection is done, press "start readout"
3.	<p>The readout archives are now stored under the selected name in the branch Devices - <Serial number/Name> - Archives respective archive readouts. See the example.</p>  <p>Every time enSuite reads out, an Archive readout is created — it displayed exactly what was read out - sorted by an ordinal number.</p>
4.	Disconnect the device (⇒see chapter 8.1.2) and view the data in a table. To do this, select the archive and click at the bottom of the navigation window on " Show Archive ".

For readout and storing of archives in enSuite, the operator must execute appropriate intervals.

Pour lire et stocker des documents sur enSuite, l'opérateur doit accomplir ces opérations aux intervalles appropriés.

It is only under this condition that the information from the logs can still be accessed if it is already deleted, or overwritten in the device.



Il n'y a qu'à cette condition que les renseignements des journaux de bord peuvent être consultés même s'ils ont déjà été supprimés de l'appareil ou s'ils ont été écrasés.

Empty or delete the archive is only possible if the rights exist and the SSW is open.

Il n'est possible de vider ou de supprimer le document que si les droits existent et que le SSW est ouvert.

The archives window appears and displays the contents of the selected archive in a table and (if possible and chosen) in a chart.

The ordinal number and the archiving time are displayed on the left. In the further course of the line, the archived data is displayed.

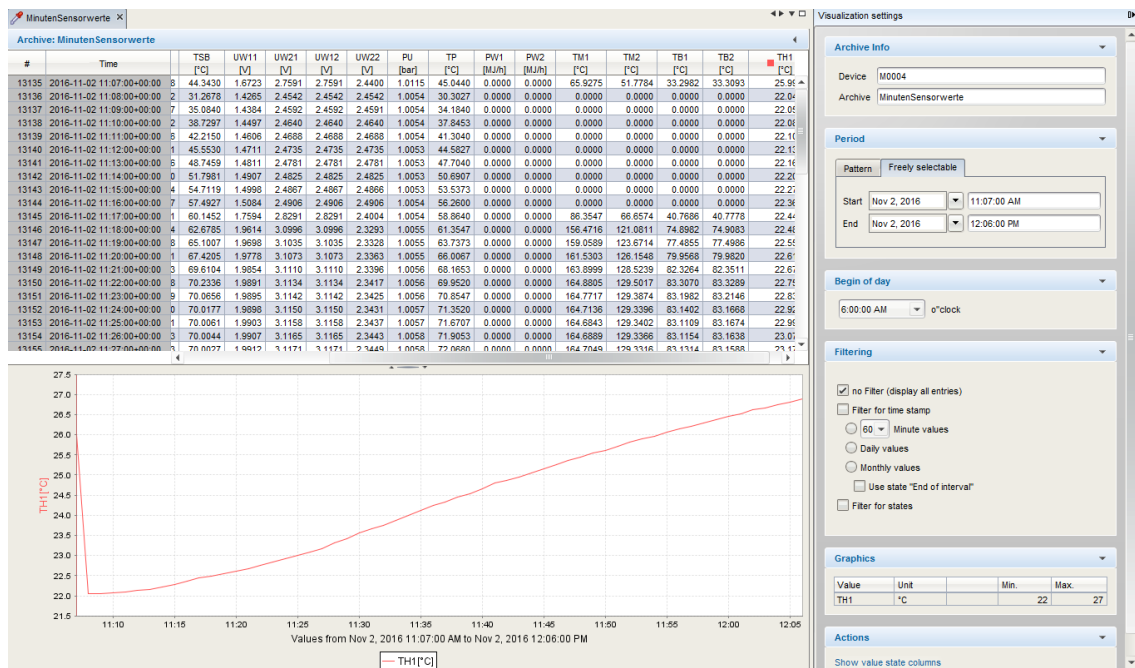

Use the "scrollbar" (if displayed) to make even more archive entries visible. Depending on the type of data, a visualization window is displayed on the tab.

There you can view selected data as a graphic. The selection is made in the context menu with a click in the header.

There is a clear association between date, ordinal number, and a time stamp for each entry.

On the right hand side, a window with visualization settings appears. You can filter the display and specify in which kind of archive channels (data) are to be displayed. Use the "scroll bar" (if available) to see all options.

8.4.6 Function “Live data and trending“

With this function EnSuite offers the possibility to view live data of the device shown as numerical and graphic value. First of all, you need a connection to the device (⇒see chapter 8.1.2). After you have gained access to the Q2, you can right-click on the Q2-symbol (on the left hand side window). In the appearing list (navigation window lower part) select the item “**Live data and trending**”. The parameters are read from the Q2 and then a new tab opens in the middle of the screen (see figure).

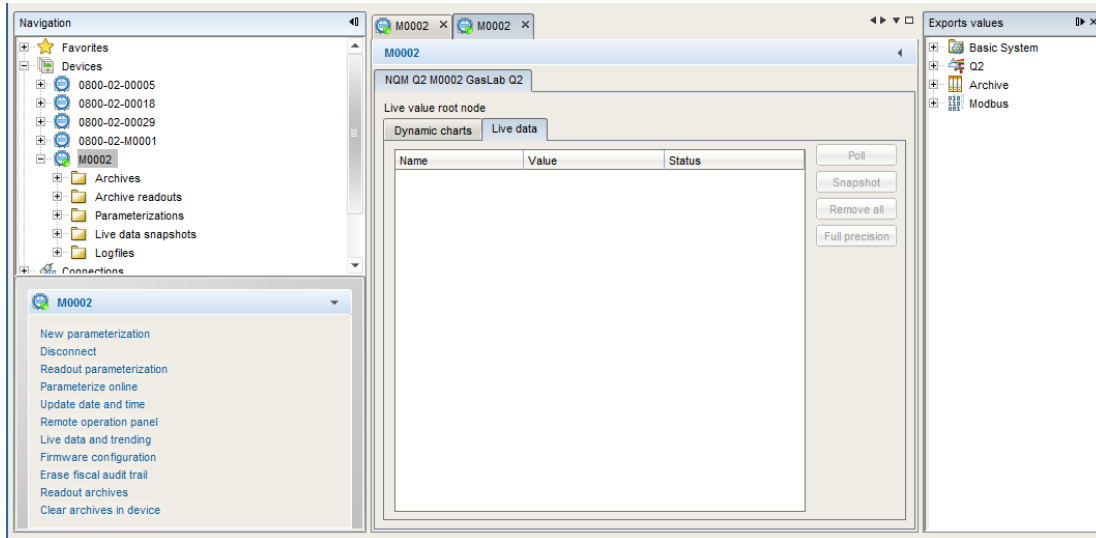

In the window are 2 tabs tabs „**Dynamic charts**” and “**Live data**”. In the tab “**Live data**” you can monitor many different types of data simultaneously, but you will only see the numerical value. In the tab “**Dynamic charts**” you can monitor just 2 *groups* of values in a graphic. *Significance of group*: while there are at most 2 vertical axes possible, there are only two positions to place the unit of the value. As a consequence, you can place many different types of data here as long as they fall into no more than two unit categories, i.e. if you already monitor 2 temperatures (in °C) and 1 pressure (in MPa), the possibilities are exhausted.

Examples of application

Tab “live data”

On the right side, there is a window showing all the values available in the device in a parameter tree. You simply navigate to the value you want and click and drag the value to the middle window (see following image detail).

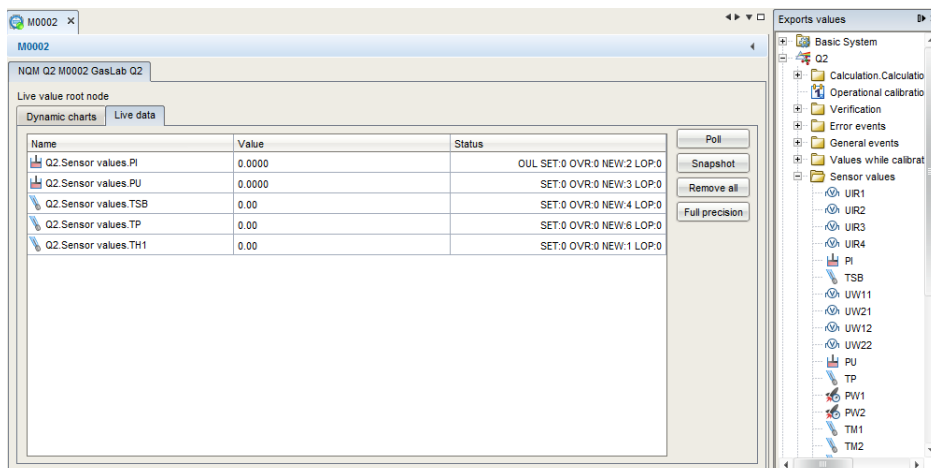

If you want to see a computed value e.g. the heating value (inferior calorific value) you have the option to view all 3 different states of the gas (completely dry / completely wet / partly wet). When you drag the desired values from the right window to the middle window, just press the "Poll" button and you will see new values every second. The button changes to "Suspend".

If you press the "Snapshot" button, the current value freezes and can be viewed in a simultaneously created new spreadsheet.

Name	Value	Status
Q2.Sensor values.UIR1	479.44	SET:0 OVR:0 NEW:7 LOP:0
Q2.Sensor values.UIR2	1256.35	SET:0 OVR:0 NEW:7 LOP:0
Q2.Sensor values.UIR3	542.38	SET:0 OVR:0 NEW:7 LOP:0
Q2.Sensor values.UIR4	539.11	SET:0 OVR:0 NEW:7 LOP:0
Q2.Sensor values.PI	1.0079	SET:0 OVR:0 NEW:7 LOP:0
Q2.Sensor values.TSB	70.00	SET:0 OVR:0 NEW:7 LOP:0
Q2.Sensor values.UW11	2058.91	SET:0 OVR:0 NEW:7 LOP:0
Q2.Sensor values.UW21	3222.84	SET:0 OVR:0 NEW:7 LOP:0
Q2.Sensor values.UW12	1483.34	SET:0 OVR:0 NEW:7 LOP:0
Q2.Sensor values.UW22	2425.43	SET:0 OVR:0 NEW:7 LOP:0
Q2.Sensor values.PU	1.0206	SET:0 OVR:0 NEW:7 LOP:0

When button "Full precision" is pressed, values are displayed in extended fashion and in digits. If you select "Remove all", the view window in the middle is emptied.

Tab "Dynamic charts"

You can select values that you want to see in a graphic. Drag the values from the right pane in the central window. Please remember the "group" notes (see above). After the desired values are placed in the middle window, press again the "poll" button. Next, the values will show up in a line graph. The button changes to "suspend" (as shown below) and "freezes" the graph, when activated, until a new click on "poll" populates fresh values.



With the button "Remove all", you can empty the center and use it for other values. The numerical ranges of values are provided in the Y axis, and the time of recording is displayed as X axis.

8.4.7 Use approval file (optional)

For devices that are to be used in fiscal metrology, a file in the device called “**Approval file**” provides an order, which parameters are relevant as a fiscal base and monitors these parameters for any changes.

There are different country-specific approval files, which determine the parameters and the corresponding values to be monitored. There are also files which allow to use this protection mechanism in non-fiscal operation.

If in the left part of the parameterization window the root of the tree (i.e. the device name) is selected, you see on the right side in the in the top row the selected approval displayed behind “**Approval file**”. If this protection is deactivated “**none**” is shown like in the figure.

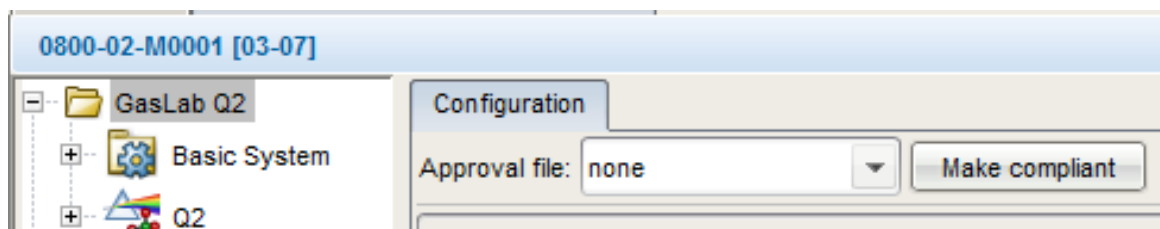

Figure 8.18: Configuration choose approval file



If you want to operate the device with an approval file, you should contact the Elster GmbH, which will close the SSW and add the necessary pieces of software.

When selecting an approval file, (also the drop-down list) the access rights for fiscal-relevant parameters and the software versions of the fiscal software components in all parameters are checked for conformity with approval.

All parameters and parameter branches that deviate in their access rights and do not meet the requirements in the approval file are marked in **bold orange**.

By clicking on “**Make compliant**” the access rights to the parameterization are modified so that the terms of the authorization are adhered to. The orange marker changes to blue, thus indicating a change from the stored parameter setting.

Changes to the values of parameters are not affected by this action. After saving all colored markers will be no longer displayed. Transfer this conformity parameterization in your device in order to use it in fiscal metrology.

While operating, the device now checks whether the fiscal access rights and the versions of the fiscal software components continues to conform to the provisions of approval file. In the case of deviations, the approval file is displayed in the device display “**System Software status**” (see figure 7.12) in red letters instead of in blue letters.

The lower part of **AFB configuration** tab shows a table of all available AFBs for the device. To extend the AFB configuration, please contact your account manager at the Elster GmbH under www.elster-instromet.com.



For more information, refer to the online help.

9 Maintenance and repair

To ensure long-term use of the device, a regular weekly operational calibration (see chapter 8), a yearly service calibration with maintenance / cleaning and if required, repair is necessary.



The Elster GmbH recommends documenting the service calibrations, maintenance work, and the operation history.

9.1 Maintenance

Maintenance consists of a review of the entire system, and preventive inspections. Use the steps below to check the range of consumables and the presence of unusual damage that may have occurred since installation and commissioning. The regular maintenance interval is 1 year. However, this monitoring can also be carried out independently in order to detect deviations at an early stage.



The regulations on explosion protection (for example, according to IEC EN 60079-14) must be observed. In addition, the operator must regularly check all safety devices for functionality, possibly even outside the maintenance interval.
Les réglementations en matière de protection contre les explosions (par exemple, selon la norme CEI EN 60079-14) doivent être respectées. En outre, l'opérateur doit vérifier tous les dispositifs de sécurité régulièrement pour voir s'ils fonctionnent bien, et ce, peut-être même en dehors de l'intervalle d'entretien.

Working steps	
1.	Check the device and area around (gas connections, gas lines) with a methane detector. If you discover a leak, shut off gas supply and seal leak. If not possible, please inform the Elster GmbH:
2.	Check the battery capacity on the display " device monitor ", if this is more than 50%, the battery can be used another year. In case of less than 20 % capacity left, inform Elster GmbH for battery replacement.
3.	Check the device for damages and loose parts. Please inform the Elster GmbH if parts are damaged. Tighten loose parts. Use the existing fix systems (screw locking device) e.g. at the connection box.
4.	Monitor the vent line / breathing element. There should be no contamination or clogging. If any, clean or inform the Elster GmbH. Do not pour or spray water or cleansers in the breathing element system!
5.	Check fluid connections and electrical cables to see if they are undamaged. If not, replace damaged components. If not possible or spare parts are required, please inform the Elster GmbH.
6.	Check the connection box (unscrew the cover. Observe the explosion protection!) The inside must be undamaged, and there are no loose cables. If not replace faulty components and connect wires according to the wiring diagram. All unused openings must be closed or shall be closed. If this is not possible or if spare parts are required, please inform the Elster GmbH.
7.	Read the cylinder pressure off the calibration gas at the pressure gauge. Note: You can use the cylinder up to a minimum pressure of 0.5 MPa. The exchange must be made independently of the maintenance interval. If necessary, replace the calibration gas mixture. See chapter 5.3.4 and 7.3.3.
8.	Check input pressures. If pressure is not between 0.15 MPa (g) and MAX, correct the pressure.
9.	Check the flow. The ball in the rotameter must be in the area between the lower and upper marks. If not, reconfigure the flow. If not possible with a valid input pressure, change the gas inlet filter. ⇨ See chapter 9.2.
10.	Recommendation: Record the results of the work and results as per items 1 - 9



To clean the Q2, ideally use a damp cloth. Usually, a mild detergent solution or a mild glass cleaner can be used, as for household purposes.



For cleaning, only use tools that will not accumulate static charge and generate sparks. It is forbidden to pour or spray water or detergent into the breathing element!

Do not use a pressure washer or something similar!

Pour le nettoyage, n'utilisez que des outils qui ne permettront pas l'accumulation de charge statique et ne créeront pas d'étincelles. Il est interdit de verser de l'eau ou du détergent directement dans 'le reniflard'! N'utilisez pas un nettoyeur haute pression ni un équipement similaire de nettoyage!

9.2 Perform service calibration yourself.

An annual service calibration with two special gases is necessary to maintain the accuracy of the measurement (if necessary, it can more often be performed). It is recommended to have this calibration carried out by the Elster GmbH or of Elster authorized / trained persons, in order to prevent malfunctions after an unsuccessful calibration and to avoid extra costs for the special gases. In non-fiscal operations, you can also perform the service calibration yourself. In the following, you will find the corresponding instructions. The required gases are given in chapter 10 and in the enSuite online help.









A gas inlet (usually the calibration gas inlet) must be connected to the service calibration gases for this process. Observe all safety instructions when working on gas connections!

Une entrée de gaz (généralement l'entrée de gaz d'étalonnage) doit être connecté à du gaz d'étalonnage de service pour ce processus. Respectez toutes les consignes de sécurité Lorsque vous travaillez sur les connexions de gaz!

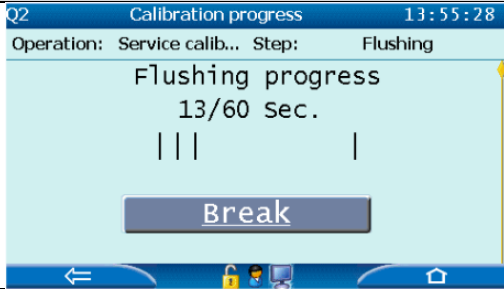
Requirement: You must be logged in and no sensor errors are detected.

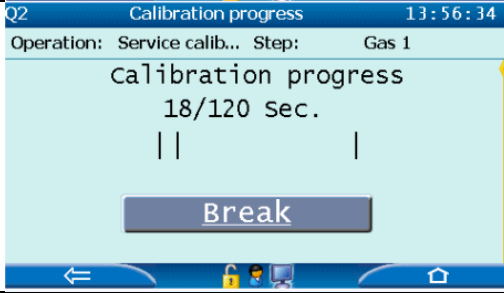
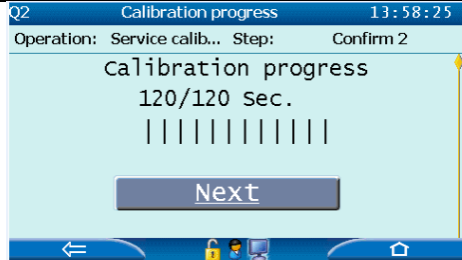
The components and gas inlets of the used service calibration gases must be stored in the device before running the service calibration. The selection and input of these values can be carried out via enSuite on the "service calibration" page. The **online help** supports you.

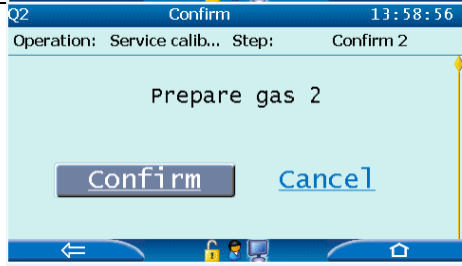
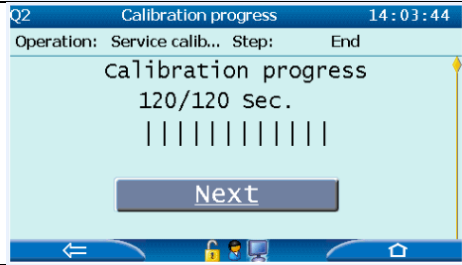
Working steps	
1.	Transfer parameterization into the device.
2.	Activate: -> -> -> and login. Navigate to Q2 control and select
3.	Activate:
4.	<div style="display: flex; align-items: flex-start;"> <div style="flex: 1;"> </div> <div style="flex: 1; padding-left: 10px;"> <p>connect the gas 1 (offset) to the selected gas inlet in a proper manner and click "confirm"</p> </div> </div>

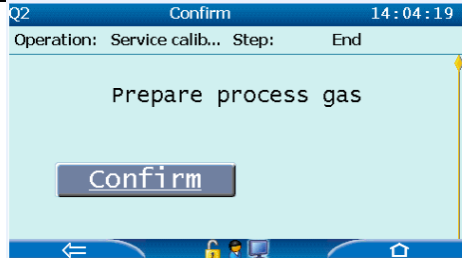
Working steps		
5.		 <p>Procedure now starts automatically. First, rinse with calibration gas mixture. This is displayed, as is the duration of the operation.</p>
6.		 <p>The first service calibration gas is then measured. The duration of this process is also displayed again.</p>
7.		<p>If you want to abort the process prematurely, you can end the calibration from point 4 by selecting "cancel / break". The device now interrupts the calibration process and prompts you for further action to return to the analysis mode.</p>
8.		<p>After measuring the 1st gas, the following display appears and initiates the 2nd part of the calibration. Select "Next"</p> 
9.		<p>Connect the second service calibration gas (gain) to the calibration gas inlet properly and click on "confirm"</p> <p>The procedure from step 5 and 6 is now repeated.</p> 
10.		<p>After measuring the 2nd gas, the following display is displayed and initiates the changeover to the analysis mode. Select "next"</p> 
11.		<p>Re-establish the original connection and perform a leak test. Activate the button "confirm". Afterwards, all gas connections are prepared again for normal operation.</p> 



The message from point 11 is displayed independently on the actual selected gas inlet. Restore the connections as they were before the service calibration.

Test the tightness!

Le message du point 11 apparaît indépendamment de l'entrée de gaz réelle sélectionnée. Restaurez les connexions telles qu'elles étaient avant l'étalonnage du service.

Testez l'étanchéité!

9.3 Repair and Elster service work

The device has hardly any consumption and wear parts. The Elster GmbH recommends an annual inspection of the filter in the process input in order to prevent errors and to carry out the service calibration with special gases.



The service calibration in fiscal operation and all other work, which require an opening of the device, should be carried out only by the Elster GmbH or by Elster authorized / trained persons for safety reasons.



The instrumentation compartment may only be opened by Elster approved personnel.

Le compartiment d'instrumentation de l'appareil ne peut être ouvert que par le personnel approuvé par Elster.

These specialists must additionally observe the service manual.

Ces professionnels doivent en plus respecter les instructions de ce manuel.

Irrespective of this // Indépendamment de ce qui est toujours:

DO NOT OPEN GASLAB Q2 IN AN EXPLOSIVE ATMOSPHERE

N'OUVREZ PAS LE Q2 DANS UN ENVIRONNEMENT EXPLOSIF

DISCONNECT POWER BEFORE OPENING

ÉTEIGNEZ AVANT L'OUVERTURE

Please contact Elster to arrange an appointment. This service offers also to solve other possible occurred problems during maintenance or could be used to check the process gas inlet filter and for repairs.

Please note: For the scope of fiscal metering, the presence of a fiscal verification officer may be additionally required, when you open the instrumentation area.



In the case of damage and for a service work appointment, please get in contact, using the contact details on page 3 of these Operating Instructions. Spare parts and substitution parts for work you can carry out, can be obtained from this address too.

Do not take a safety risk by using incorrect substitution parts. Only original spare parts of Elster GmbH may be used. No liability shall be accepted for damages resulting from the use of unauthorized spare and substitution parts.

The process gas inlet is equipped with a filter to protect the interior of the device from contamination. It can clog when feeding non-specification-compliant gas or by failure of the upstream filter system. If the filter is clogged, it must be replaced.



Since the filter is neither visible nor accessible in normal operation, clogging can only be determined by means of external reactions. Example "process gas pressure alarm" is displayed and the device meets all conditions specified in chapter 10. If there is any suspicion of clogging, please contact the Elster GmbH to do more tests or exclude other causes.

After several years of operation of wear and aging, additional maintenance and repair may arise. Examples are battery replacement (approximately 10 years) and replacements of seals and IR-transmitter!

Similarly, factory maintenance must be carried out, if non-remediable deficiencies occur at the annual services or the housing is damaged. This work requires, depending on situation, the opening of device, complete disassembly or a return to the Elster GmbH. The required work (with the exception of the complete device replacement) can only be done through Elster Service or by Elster trained staff.

For example, the housing may only be repaired by the Elster GmbH because dimensions of the flameproof joints are detailed in the manufacturer's design documents and are not part of an individual's general knowledge. Please contact the Elster GmbH.



Explosion-proof equipment not repaired by the Elster GmbH may be not used again until it has been checked by an accepted expert and matches the manufacturer's design documents.

L'équipement antidéflagration non réparé par Elster GmbH ne peut être utilisée à nouveau jusqu'à ce qu'il ait été vérifié par un expert reconnu et qu'il conforme de nouveau aux documents de conception du manufacturier.

10 Technical data and notes

The essential technical data is shown on the various type plates and labels directly on the device and are reproduced here below. Supplementary tables and the CE declaration complete this overview.

10.1 Tables and information additional to the device

Q2 system	Values and / or comment
Location of use	Installation close to the sampling point up to zone 1
Mounting clearance	left and right at least 300 mm / top and bottom at least 200 mm / free space (recommended 900 x 900 mm)
Gas group	Only appropriate gases as mentioned below. It is not allowed to supply gasses that can react in the absence of air!
Gas ports */ gas connection	Input (1 x process gas. 1 x calibration gas mixture) Output (1 x process gas bypass 1 x measurement gas) Swagelok fittings 6 mm or ¼ " can be supplied by Elster
Breathing vent line	Breathing element connection: 1/4 "NPT
Gas management	Integrated 2-channel double block and bleed device for process gas and calibration gas.
Size of housing /dimensions	H = 38cm, W = 27cm, D = 23cm
Weight	Approximately 16kg
Voltage	24 V DC fluctuation, including mains fluctuation ±15%
Maximum current / power**	4 A / 96 W (includes housing heater 30 W)
Pollution degree of macro environment	4
Operation panel	Color display 9.5 x 10.5 cm (illuminated); 7 key captive touchpad 2 multi-colored LEDs for indicating the power supply and status
Heat-up time	At -25 ° C up to 1 h
Dynamics	Analysis rate f=1 Hz, reaction time $t_{90} \geq 6s$ (90% step response / Tested @ NMi)
Operational calibration interval setting	1 week
Service calibration interval	1 year
Data memory (non-volatile):	Archives / calibration data / parameterization / logs
Operating system	Service PC: Refer to the download area of Elster
Software	enSuite
File format:	enSuite.csv / enSuite.par
Data logger	Integrated (logger interval adjustable)

*Standard equipment other connections available on request

** Nominal 96W during start up. Once at temperature reached measurement conditions and depending on the ambient air, the power may drop to 20W

±15% is including mains fluctuation

The Ex classification	
ATEX	II2G Ex db IIC T4 Gb
IECEX	Ex db IIC T4 Gb
FM(us)	Class I Zone 1 AEx db IIC T4 Gb / Class I Div 2 Groups ABCD T4
cFM	Ex db IIC T4 Gb / Class I Div 2 per CEC J18-150
According to the standards:	
IECEX:	IEC 60079-0 2011 6th edition IEC 60079-1 2014-06 7th edition
ATEX:	EN 60079-0 2012 + A11 2013 EN 60079-1 2014
FM standards	Class 3600 2011 Class 3810 2005
ANSI:	ANSI/ISA 60079-0 2012 ANSI/UL 60079-1 2015 ANSI/ISA 61010-1 2012
CAN/CSA	C22.2 No. 0-4 2013 C22.2 No. 0-5 2012 C22.2 No. 0-10 2015 C22.2 No. 61010-1 2012 C22.2 No. 60079-0 2015 C22.2 No. 60079-1 2011

Range of appropriate gases (generic natural gases)				
The gases must be technically free from dust and liquids!				
Component name	Formula	Measurement range OEML R140	Technical range	Output
Methane	CH ₄	70 – 100 mol%	70 – 100 mol%	Yes
C ₂ H ₆ + higher alkanes (sum)	C ₂ +	0 – 15 mol%	0 – 20 mol%	Yes
N ₂ -concentration	N ₂	0 – 25 mol%	0 – 25 mol%	Yes
CO ₂ -concentration	CO ₂	0 – 20 mol%	0 – 20 mol%	Yes
O ₂ -concentration	O ₂	≤0.1 mol%	≤0.1 mol%	No
H ₂ -concentration	H ₂	≤0.1 mol%	≤0.1 mol%	No
Water (gaseous)	H ₂ O	≤0.1 mol%	≤0.1 mol%	No
Hydrogen sulfide	H ₂ S	≤5 mg/m ³	≤5 mg/m ³	No

Calibration gas	Range
Mixture (Methane +CO2)* Blend tolerance: ± 2% rel. accuracy : ± 2% rel.	automatic calibration cycle. Flow calibration gas: 30 l/h - 60l/h during calibration Setting 0.2 MPa Range (0.2 MPa (gauge) ± 0.05MPa)
10 l gas cylinder : (not always part of Elster)	Make sure the cylinder pressure is higher than 2 MPa (g) and use a type that meet the specifications and standards, if not delivered by the Elster GmbH. Further required accessories: Pressure regulator and connection lines

*The mixture depends on the gas to be measured. Please use an appropriate gas from the following table

Actual measurement Range CO2		Preferred gas for	
		operational calibration	service calibration
min 0	max 4 mol %	2 mol% CO2 + CH4 balance	5 mol% CO2 + CH4 balance
min 0	max 20 mol %	10 mol% CO2 + CH4 balance	20 mol% CO2 + CH4 balance

Environmental specifications	Value and Comment
Environmental pressure	Atmospheric Pressure
Environmental temperature	-25 °C to +55°C
Damp	0-100%RH
EMC: Immission	Electrostatic discharge according: IEC 61000-4-2 [25]
Mech. Stress	Vibration according IEC 60068-2-64 [20]; IEC 60068-2-47 [19]

Inputs / outputs (I/O)	Values and / or comment
Communication:	Speed: 345600 Baud Type of interface TCP/IP (serial interface) (only for connection box)
Analog outputs:	Quantity 4 (common ground, 0/4...20mA galvanic isolated) Short circuit protection R max = 390 Ω
Digital outputs:	Quantity 4 (common ground, galvanic isolated) 1 xNC (Normally closed suitable for general alarm) 3 x NO (Normally open) Semiconductor circuit operates as a potential-free contact max.120 mA at 28,8V (DC)
Digital inputs:	Quantity 2 (2 wire lines, device powered max. 9 V, galvanic isolated). e.g. process and calibration gas pressure control option
Ethernet communication:	1 x Ethernet (TCP/IP; Modbus; ftp; http)
Serial communication:	2 x RS485 (Modbus serial)
Operational interface	7-channel capacitive touch panel

10.2 Inscriptions and hints on the device

The spatial arrangement and the contents / meanings of the inscriptions and signs are stated below. These preconditions must be strictly followed.

10.2.1 Metering ranges and safety notes

The information about gas, approved metering ranges and the safety notes about opening the housing are on the lid of the connection box.

DO NOT OPEN WHEN POWER IS ON	
DO NOT OPEN WHEN AN EXPLOSIVE ATMOSPHERE IS PRESENT	
	Metering ranges NB0122 EC TC8494R1
<p>Nature of the measured gases: Natural Gases and Natural Gas-like burnable Gases Process Gas flow : Qmin 20 l/h Qmax 310 l/h Calibration gas flow : Qmin 20 l/h Qmax 60 l/h Gas temperature : Tmin -25°C Tmax 55°C Accuracy class: Hs: Class A ($\leq 0.5\%$), p: Class A ($\leq 0.5\%$), xCO₂: ≤ 0.2 mol % Heating value (Hs / HsM / HsV): 8.4 to 13.1 kWh / m³ (corresponding to 30.2 to 47.2 MJ / m³) Climatic and mechanical class : I (indoor) and O (outdoor) Concentration of CO₂ mole fraction : 0 - 20% Density at base conditions (Rho) : 0.711 to 0.970 kg / m³ Determination of the compressibility factor according to the selected standard (ISO 6976 or GPA 2172 or ASTM 3588)</p>	

Figure 10.1: Metering ranges

Details and more metering ranges see following table:

Measurements and ranges	Measurement name	Formula	Range	Output
	Heating value #	H _s	30 – 48 MJ/m ³ *	Yes
	Standard density #	(rho)	0.7 – 1.1 kg/m ³ *	Yes
	Wobbe index #	W _{I_s}	33 – 57 MJ/m ³ *	Yes
	Dry/wet/saturated CV #			Yes
	Inferior CV and Wobbe #	H _i , W _{I_i}		Yes
	Methane number	MZ		Yes
	Calculated model gas quality	CH ₄ ...C ₈ H ₁₈ , N ₂		Yes
	* according to ISO 6976 at T ₁ =25 °C, T ₂ =0 °C			
	# according to ISO 6976, ASTM 3588, GPA 2172 at all known reference conditions			
Accuracy	Class A according to OIML R 140 for a CVDD			
Uncertainty	H _s , W _s , : $\leq 0.5\%$, xCO ₂ : ≤ 0.2 mol%			
Repeatability	H _s , W _s , : $\leq 0.1\%$, xCO ₂ : ≤ 0.1 mol%			
Drift	H _s , W _s , : $\leq 0.1\%$, xCO ₂ : ≤ 0.1 mol% during adjustment interval			

10.2.2 Type plates

The type plate with the most important information is located under the operation panel, behind the sight glass. These information must be observed and complied with in every case. If the type plate is covered by the sand protection, this information can be read on an additional type plate outside of housing. The following figure shows the position of the type plates.

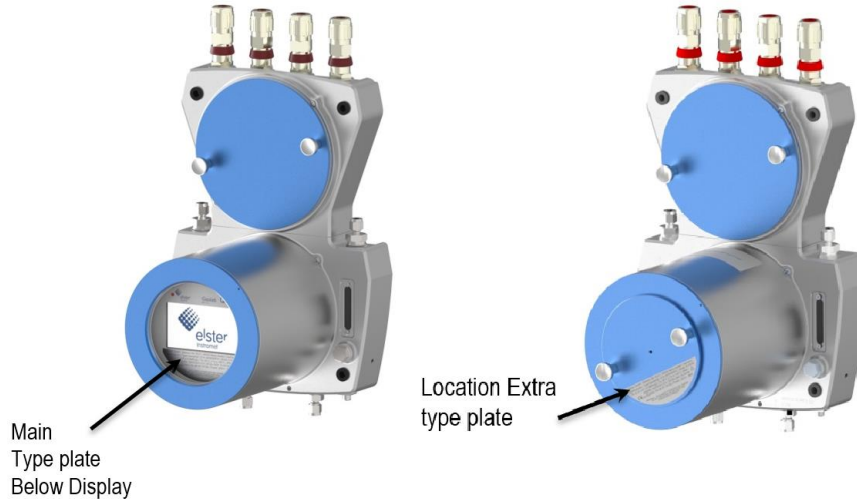

Figure 10.2: Example position of main type plate

Depending on distribution area of the device, the type plate varies in the language and in the list of included standards or regulations. See type plate examples below.



Type plate variations	Information
	<p>Manufacturer and manufacturer address with the address of the production site</p> <p>Kind of device type designation serial number and year of manufacture MM / YYYY</p> <p>2 D-matrix code and warning mark to read the manual</p>
	<p>Gas input pressure range *</p> <p>Ambient temperature range</p> <p>protection class (IP)</p> <p>Voltage and power consumption</p> <p>Procured approvals**</p> <p>(For EU) approval number DEKRA 15.ATEX0113X / IECEx DEK 15.0075X</p> <p>CE mark with auditor number</p>
	<p>Approval number FM: FM17US0040X / FM17CA0027X</p> <p>Class I Div 2 Groups ABCD T4</p> <p>Explosion classification: (II 2G) (A) Ex db IIC T4 Gb (for ATEX IECEx and FM)</p> <p>Warning and connection notes for several languages on extra label</p>

Figure 10.3: Example main type plate

* On request, devices for 0.05 MPa (g) inlet pressure are available

** Not all certificates and approvals are listed here. The information on the device applies!

10.2.3 Extra additional markings

On the functional housing lower part of the device are the following markings: Level marks  for the gas flows bypass (left) and calibration process (right) Arrows  for the direction of the gas flows, maximum inlet pressure of process gas **PG** and calibration gas (cylinder) **CAL**

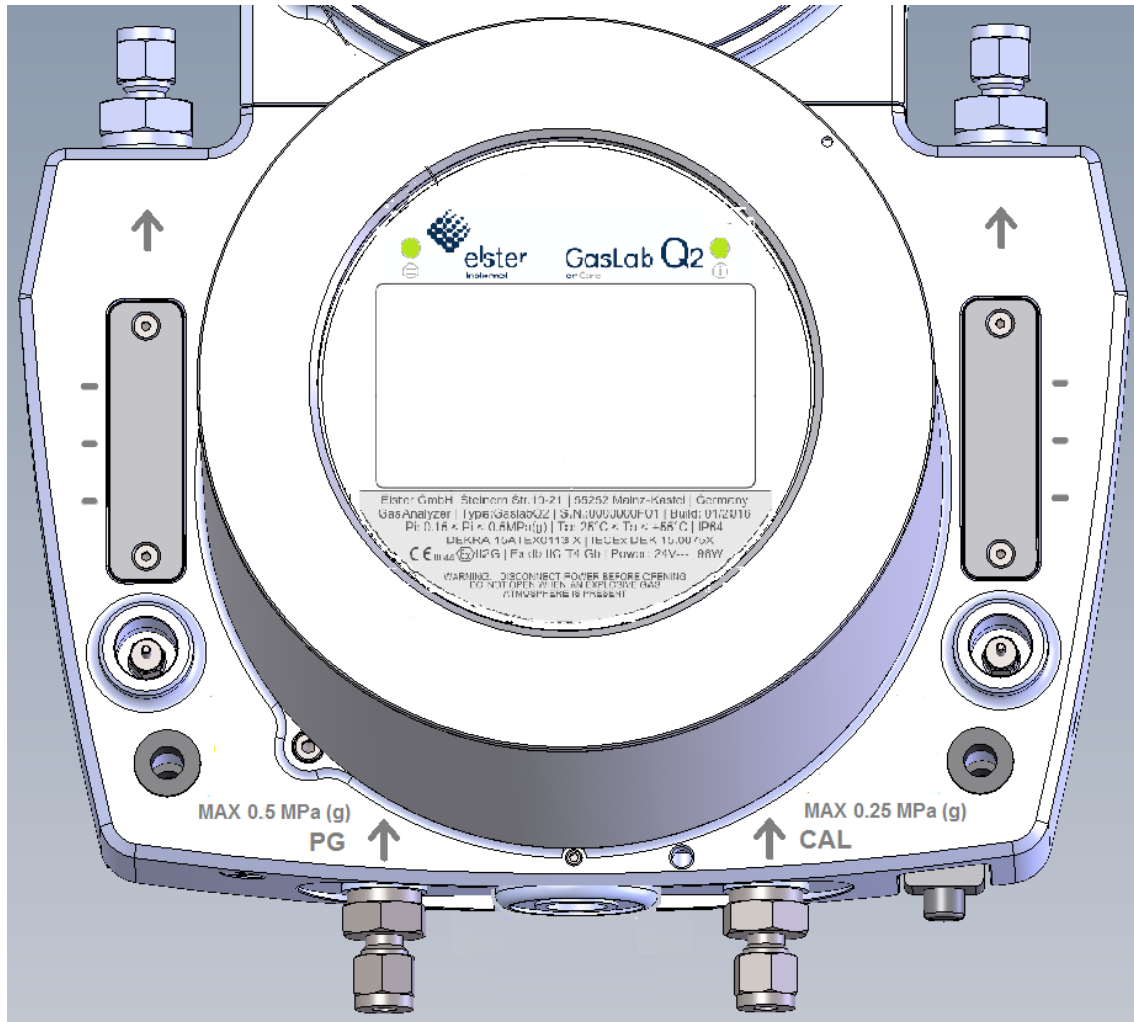

Figure 10.4: Extra marks on the device

The ball of the left flowmeter begins to float at about 55 l/h. Marks indicate the flows of about 90 l/h (bottom) 125 l/h (middle) and 160 l/h (at the top). On reaching the upper end, the maximum flow is set to approximately 310 l/h.

The marks on the right flowmeter show the usual flows of about 30 l/h (below) approximately 40 l/h (middle) and 60 l/h (top).



The flowmeters are only used for a rough estimation of the flow rate. If the ball is within the three markings, sufficient flow is available for operation. A gas flow also exists in the case of stationary balls. It is also possible to adapt the gas flow above the maximum mark. Elster recommends the use of an additional flow meter in cases where the exact flow rate is critical. (After the setting process, this can be removed again.)

10.3 Declaration of Conformity

The EU Declaration of Conformity lists all certificates and approvals. The following is a section of the CE declaration. You can download the complete Declaration of Conformity and related documents in PDF format from our Docuthek (www.docuthek.com).

Type, model **GasLab Q2**

Manufacturer **Elster GmbH, Steinern Straße 19-21, 55252 MAINZ-KASTEL, GERMANY**

Product **Caloric value determining device (CVDD)**

This declaration of conformity is valid for the following Directives:

2014/30/EU (EMC)	2014/34/EU (ATEX)
-------------------------	--------------------------

The object of the declaration described above is in conformity with the relevant Union harmonization legislation:

EN-IEC 61326-1:2013	EN 60079-0:2012 + A11: 2013, EN 60079-1:2014
---------------------	---

Certificates and interventions by notified bodies:

n.a.	DEKRA 15 ATEX 0113 X
n.a.	EC type examination <i>EG type examination</i>
n.a.	Notified Body 0344 DEKRA Certification B.V. Meander 1051 NL-6825 MJ Arnhem

This declaration of conformity is valid for products labelled accordingly:

	
---	--

The production is subject to the following surveillance procedures:

Directive Annex II <i>Richtlinie Anhang II</i>	Directive Annex IV+VII <i>Richtlinie Anhang IV+VII</i>
n.a.	Notified Body 0044 TÜV NORD CERT GmbH D-30519 Hannover

11 Appendix

11.1 Nomenclature





The following symbols and notations (abbreviations) are used in the documentation and in enSuite:

Shorthand	Description
AFB	Application Function Block (enSuite)
ATEX	Atmosphère explosible (French for explosive atmospheres)
C2+	Summary of results (ethane + all higher hydrocarbons)
C2H6	Ethane
C3H8	Propane
C6H14	Hexane
C7H16	Sum heptanes
C8H18	Sum octanes
CAL	Calibration gas inlet
CEC	Canadian Electrical Code
CH	Sum of all hydrocarbons
CO ₂	Carbon dioxide
CPU	Central Processing Unit
CVDD	Calorific value determining device
d	Relative density (of fuel and air)
DBB	Double block and Bleed (name of valve block technique)
DC	Direct current
DHCP	Dynamic Host Configuration Protocol
DIN	Deutsches Institut für Normung e. V. (German Institute for Standardization)
DNS	Domain Name System
EN	European Standard
FE	functional earth
Hi / HiM / HiV	Net heating value; molar / based on mass / based on volume
Hs / HsM / HsV	Gross heating value; molar / based on mass / based on volume
Hz	Frequency
iC4H10	Isobutane
iC5H12	Isopentane
ID	Identification number (enSuite), for example gas cylinder number
IP	Internet Protocol
IR	Infrared
ISO	International Organization for Standardization
K	Kelvin Temperature unit ($\Delta 1K = \Delta 1^{\circ}C$)
KFM Live	internal coefficients and filters
LED	Light emitting diode
log.	Logbook
m	Mass
M (Mm)	molar mass (of the mixture)
MPa	Mega Pascal (pressure) 1 MPa = 10 bar
MPa (g)	Mega Pascal (gauge) (overpressure)
MZ	methane number
N ₂	Nitrogen
NC	Switch / output normally (without energy) closed
nC4H10	n-butane
nC5H12	n-pentane
NEC	National Electrical Code (USA)

Shorthand	Description
NO	Switch / output normally (without energy) open
NPT	National Pipe Thread (self-sealing (pipe) thread)
NTP	Network Time Protocol (standard for synchronizing clocks in computer systems)
O2	Oxygen
PC	Personal Computer
PE	Protective Earth
PELV	Protective Extra Low Voltage
PG	Process gas
PI	Pressure internal (internal check)
ppm	parts per million
PU	Ambient pressure (internal check)
PW1 / PW2	Internal calculation values
Rho	Density at base conditions(Standard density)
RS 485	Interface standard wired differential serial data transmission
SFB	System function block
SSW	Security Switch
TB1/TB2	Internal calculation values
TCP	Transmission Control Protocol (Internet)
TH1	Housing temperature
TM1 / TM2	Internal calculation values
TP	Board temperature (internal check)
TSB	Temperature Sensor Block
VDE	German Association for Electrical, Electronic & Information Technologies
Wi	Net Wobbe index
Ws	Gross Wobbe index
Z	Compressibility factor

11.2 Definitions and explanations

Term	Explanation
Alarm	Alarms are errors that compromise the accuracy of the results. An alarm is generated, for example, when a measured value is outside the defined measuring range. Comings and goings of an alarm are registered with time stamps in the associated error list. When an alarm is no longer present, and is no longer current, it can be accepted and thus removed from the error list.
Analysis	is the mode in which the device carries out systematic inspections of gas and thus, are the normal measurement conditions.
Approval file	is an enSuite file which contains different country-specific approvals and determined which approval for the device shall be applied. It lists the parameters that are specially protected, contains all fiscally relevant AFBs and the text passage of approval.
Audit trail	is a two part protocol archive (parameter change archive) and gives the user the option of changes, relevant to payroll, without opening the security switch (SSW). These changes will be monitored in the fiscal part and documented. The data can be viewed on the device screen and copied with the help of enSuite. If SSW is open, only records in the general part are made.
Base calibration	Before a device is delivered, a base calibration with several gases has been performed by the Elster GmbH. If necessary, they will be performed again subject to readjustments by Elster.
Basic display	is the name for a display, which includes a composition of the most important results. Where appropriate, there are further subordinate displays. The device starts with this display. The Q2 main display is the factory set basic display.
C2+	This number means that all higher hydrocarbons are collected to the ethane component.

Term	Explanation
Checksum	is a method of identification, display and control of the software version. It is calculated by the Q2 itself. More information about this enCore device used control method can be found in the instructions “enCore FC1 - Basic System with SFBs”
DBB technology	is a valve sealing technology for gas flows. Through a series circuit of two solenoid valves with a vent between them, the mixing or contamination of gases is prevented, even when there are leaks in the valves.
Display	is the collective term for all representations and views on the device screen.
enCore Flow Computer	(Abbreviated as: enCore FC) summary of different device types used as process computers. These include, for example, the enCore ZM1 status converter, the enCore MC1 monitoring and monitoring unit, and the enCore FC1 flow computer. GasLab Q2 also uses this software basis for data management.
Error List	helps the user to identify errors and reconstruct the history of the disturbance gradient. Messages are entered with the comings and goings in the error list and are recorded in the log.
Event	is generated when a measurement violates a user-specified state. The coming of such an event is logged with time stamp in the error list. These events cannot be accepted and disappear automatically when invalid. All notices will be entered in the logbook.
Export value	The functional blocks of the software make results available, which can be further processed by other function blocks. These results are called “export values”.
Fiscal parameters	are signed with one of these symbols   to give information about the change opportunities when SSW is closed. This option is not used when the SSW is open. If you operate the device with closed SSW parameter with this symbol,  changes could not be made. Parameters with this symbol  can also be changed with a closed SSW; as long as the audit trail is not full, the change will be logged there and therefore monitored.
Gas Quality Analyzers	are devices that measure the heating value of gases automatically. Heating value, density at base conditions and carbon content are determined from the values of the sensors.
Location of use	or of installation is the room or space where the device is placed. It must meet the specified requirements of the manufacturer, authorities, and operators.
Logbook	is a protocol archive that can be used by all software components. It can record all deviating situations e.g. errors from the normal measurement mode.
Message	is an event that is valid for a number of evaluation runs of the device. It can be reset by a user with the appropriate user rights
Fiscal verification officer	A person who has the ability and is authorized, because of his or her technical training, knowledge and experience, to execute fiscally protected tasks in gas systems within the scope of legal metrology. A metrology expert is trained to work with fiscally protected devices and systems, and is acquainted with the relevant standards and regulations that apply in specific countries.
Operating mode	Operating modes are states that the device can be in use.
Operational calibration gas	Also called calibration gas, is held in cylinder connected firmly to the Q2 and is part of the measuring device. It is a mixture of methane-clean gas and carbon dioxide with fiscal established properties is required for automatic calibration.
Ordinal number	archived data has a serial number (automatically assigned identification number). This is structured in such a way so that the first archive entry has the number 1 for each subsequent entry, the number is increased by one.
Process gas	is the gas which has to be analyzed or measured. It is supplied to and through the device in normal operation and is also called sample gas
Protective Extra Low Voltage (PELV)	is an electrical system in which the voltage cannot exceed extra low voltage under base conditions, and under single-fault conditions, except earth faults in other circuits (IEC 61140 defines a PELV system). Please contact the Elster GmbH in if you want to use this system because a modified wiring is required.
Security Switch (SSW)	is a possible hardware interruption and part of the concept for limiting user rights. It is a physical connection. This connection is open upon delivery. Since any change needs the housing to be opened, this may only be done by authorized persons of Elster GmbH.

Term	Explanation
Specialist	or professional is a person who has the ability, because of his or her technical training, knowledge and experience and knowledge of the relevant standards and regulations. The professional can assess completed work and recognize possible dangers. Hardware work on Q2 requires, among other skills, those according to EN-IEC 60079-14 Annex A.
Signal	is an event that is issued only briefly. An acknowledgment by the user is not required / possible signals are also entered into the logbook
Start delay	determines how long the start is delayed after reaching the measurement conditions.
Status LED	indicates whether an error affecting the legally relevant functionalities, i.e. an alarm or a warning, is pending or has been pending.
Super user	is a user which can create or delete other users in the profile belonging to. The super user is present in each parameterization and cannot be deleted.
System Time	is the combination of time and date displayed on the device. Changing the system time is the generic term for both the synchronization and adjusting of these values. For more information on Synchronization and Network Time Protocol, please refer to the instructions "enCore FC1 - Basic System with SFBs"
Time stamp	is time data given in coordinated Universal Time (UTC) and applies to an event. Time stamp contains information in seconds since 01/01/1970 as UTC, the local time zone (difference from UTC in minutes) and the local time change (additional deviation in minutes) The format for the display of time stamps depends on the language selected on the Q2; e.g. if the display format is in English, then YYYY-MM-DD hh:mm:ss is displayed, or if in German then DD.MM.YYYY hh:mm:ss is displayed, and it determines the order of selection lists for the date and time.
Time zone	can only be set via a enSuite offline parameterization and allows a selection of the UTC standard time
User management	ensures that no unauthorized changes are prevented and authorized changes are permitted.
User profile	is a set of access rights for a group of up to 10 users. A non-erasable super user, for example super user SU3 manages the profile.
User	is a person belonging to a specified user profile operating the device. The identification is done through user name and password.
Valve block	is a connector with gas channels for a plurality of valves; it is used to implement the valve circuit techniques "double block & bleed".
Verification gas	A test gas mixture of known characteristics, which is supplied in place of the process gas to the GasLab Q2 to check it.
Warning (message or signal)	Messages which do not falsify the results, but which are important for monitoring the measurement, the calculation is correctly continued. If the reason of message no longer exists, it can be reset via the panel and thus be removed from the error list.

12 Index

12.1 Keywords

A

Abbreviations 138
 Accept errors 100
 Acceptance procedure 67, 100
 Access rights (enSuite) 112, 125
 Accessories (required) 132
 Accuracy class 134
 Actions 59
 Alarm 67, 96, 139
 Ambient conditions 14, 133
 Ambient temperature 15, 30, 43
 Ambient temperature range 135
 Analog output 45, 50
 Analysis (operation mode) 52, 53, 82, 139
 Application (range / use) 14
 Application Function Block (enSuite) 104
 Appropriate gases 132
 Approval (document) 137
 Approval (explosion protection) 135
 Approval file (enSuite) 51, 66, 116, 125, 139
 Archive
 - view data table 121
 - Window (enSuite) 122
 Archive Readout / look at / saving 121
 Arcive AFB 109
 Audit trail 70, 74, 91, 92, 121, 139
 Automatic calibration 37
 Automatic logout 89, 106

B

Backup 105, 107, 117
 Base calibration 139
 Basic display 55, 60, 139
 Basic network settings 93
 Basic system (enCore) 109
 Battery 31, 51, 54, 64, 97
 Billing purposes 74
 Blind plug 28, 44
 Branching overview 62
 Breathing element 15, 27, 39, 101, 131
 Built-in extra heater 52
 Button bar (enSuite) 105
 Bypass 24, 39, 53

C

Cables 22, 28, 44, 54
 Calculation standard 79, 109
 Calculation Standard 76
 Calendar 94
 Calibration 69
 Calibration gas 140
 Calibration gas cylinder 37
 Calibration gas flow 134
 Calibration types 109
 Certificates 137
 Change language on Q2 device 62
 Checksum 140
 Climatic class 134

CO2 concentration 78, 134
 Commissioning 51
 Communication 103, 105
 Communication ports 28, 106, 133
 Compressibility factor (Z) 79
 Condensation 30
 Condensation water 51
 Connection area 23, 26
 Connection box 28, 44, 106
 Consumption and wear parts 129
 CPU-load 64
 Current output 50
 Customer Service 9
 Cylinder pressure regulator 38

D

Damaged devices 17
 Danger notes 7, 11, 13, 18, 41, 52
 Data memory 131
 Date & Time (at device) 70, 94
 Date & Time (device display) 71
 Date & Time (setting with enSuite) 119
 DBB technology 24, 140
 Decommissioning 54
 Default condition 117
 Default gateway 75, 93
 Definitions 139
 Density at base conditions (Rho) 78, 79, 134
 Details (button) 76, 78
 Device identification (enSuite) 106
 Device monitor (Display) 64
 DHCP Mode 75, 93
 Digital inputs 48
 Digital outputs 45, 49
 Dimensions of Q2 32, 131
 Disable touch 69
 Dismantling 34
 Display (definition) 140
 Display (Gas components) 69
 Display details 79
 Display Home 61
 Display Info Q2 64
 Display overview 62
 Display Q2 Calibration 69
 Display Q2 Control 69
 Display Q2 Main 76
 Display Q2 Sensor values 68
 Display Q2 Verification 69
 Display test 66
 Display User archives 80
 Displays (folder in enSuite) 109
 Displays Q2 calibration data 69
 Disposal 54
 DNS server 75, 93
 Docuthek 7
 Drop-down list 59, 86

E

Ehternet 47
 Electrical connections 44, 45

Electrical entry 17, 28, 44
Electrical installation 15, 17, 41
Electrical interface 44
Electrical protection 42
Electrical safety 15
Electrical values 131
Elster Downloads 7
Elster service 130
enCore (product platform) 104
enCore Flow Computer 140
enSuite 105
enSuite (Export window) 114
EnSuite data connection 106
enSuite installation 105
enSuite presettings 116
enSuite(start of) 105
Environmental specifications 133
Error during startup 63
Error List (Main display) 67, 96, 140
Errors (LED colors) 95
Ethernet 56
Ethernet I/F (display) 93
Event 140
Event identification 67, 73
Exhaust gas 15, 17
Exhaust gas manifold 39
Exhaust tube 15, 17, 22, 24, 39, 101
Explosion 16, 31, 34, 101
Explosion area 18
Export value 140

F

Factory setting 51, 52, 112, 117
File format 131
Fill-in fields 59
Filter 129
Filter System 36
Fiscal Audit trail 92
Fiscal operation 51
Fiscal parameters 140
Fiscal software components 125
Fiscal verification officer 51, 129, 140
Fittings 35, 41
Flame arrestor 39
Flow rate 25
Flowmeter 24, 136
Flushing (gas line) 36
Flushing process 39
Flushing times 109
Flushing times (Adaptation) 116
Functional housing part 24
Fuses (internal) 42

G

Gas analysis 78
Gas calculation values 79
Gas components 78
Gas cylinder 37, 39
Gas flow 53
Gas inlet 34
Gas lines 15, 27, 35, 40, 41
Gas management 24, 131
Gas outlet 34
Gas passage 25, 35, 41
Gas ports 24, 27, 34, 131
Gas pressure range 14, 27, 34, 135, 136
Gas properties 13, 14, 132
Gas Quality Analyzer 140

Gas specifications 13, 36
Gas supply 35
Gas supply disruption 102
Gas temperature 134
Gross heating value based on volume (HsV) 78
Gross Wobbe index (Ws) 78, 79
Grounding 41, 43, 101

H

Health hazard 7
Health of personnel 10
Heat up time 131
Heating value 79, 134
Heat-up time 53
High pressure reduction 14, 22
High pressure regulator 38
HMI interface 23
Home (button) 55
Home Display 61
Home symbol 60
Host name 75, 93
Housing 23
Housing heater 131
Hyperlinks 59

I

I/O (display) 70
Illumination (interactive screen) 81
Inactivity timeout 89, 106
Inferior calorific value 79
Infrared measuring method 20
Input filter 36, 130
Input pressure range 34
Inscriptions 134
Installation 16, 35, 40, 41
Installation (fluidic) 34, 40
Installation (location) 31
Installation (position) 32
Installation standard 44
Instrumentation area 23, 24
Intended use 10
Interactive screen 56, 81
Interface (types) 133
Internal fuses 42
IP address 56, 75, 93, 106
IP protection class 135

K

Keypad 87

L

LAN 47
Language change (optional) 62
Leak test 39, 41, 102
Leaks 17, 41, 102
LED (signal lights) 29, 95
LF pulse input 48
License info (display) 66
Lightning protection 17, 41
Limits 109
Live data and trending (enSuite) 123
Local operation panel 56
Location of installation 31, 140
Location of use 9, 15, 31, 41, 44, 53, 131, 140
Logbook 55, 70, 91, 121, 140
Logbook (Error List) 73
Login 72

Login at enSuite 109
 Login at operation panel 89
 Logout 72
 Logout (a remote user) 90
 Logout (automatic) 106
 Logout at operation panel 88, 90

M

Main display 76
 Main PE terminal 43
 Maintenance 126
 Make compliant 125
 Manufacturer's certificate of analysis 84, 127
 Measurement conditions 29
 Measurement dynamics 131
 Measurement operation 53
 Measurements 134
 Measuring principle 19
 Mechanical class 134
 Mechanical vibrations 31
 Menu bar (enSuite) 105
 Menu navigation 57
 Message 140
 Message input 48
 Message output 49
 Messages of the device 67
 Messages of Time Service SFB 96
 Metal frame 43
 Metering Ranges 134
 Metrological nameplate 134
 Misuse 10
 Modbus AFB 109
 Modbus Main display 80
 Modbus register 80
 Mounting clearance 131
 Mounting distances 32
 Mounting plate 32
 MZ (methane number) 78, 79

N

Navigation
 - via touchscreen 59
 Navigation target 60
 Needle valve right 53
 Network mask 75, 93
 Network settings 106
 Network Time Protocol (NTP) 70, 119, 141
 Nomenclature 138
 Normal operation 82
 NTP (Network Time Protocol) 119
 NTP overview (display) 72

O

Offline parameterization (enSuite) 112
 Online help 106
 Online parameterization 115
 Operating hours 64
 Operating mode 140
 Operating modes 55
 Operating pressure sensor block 25
 Operating principle 20
 Operating system 131
 Operating voltage 12
 Operation 55, 56, 57, 81
 - Verification 77
 -Analysis 77
 -Operational Calibration 77
 -Startup 77

Operation enSuite 105
 Operation mode 77
 Operation panel 93, 131
 Operation precondition 51
 Operation with operation panel 56
 Operational calibration 52, 116
 - after event 117
 - automatic 116
 - break 82
 - cycle 116, 131
 - error message 117
 - interval 117
 - start manually 82
 Operational calibration gas 24, 27, 35, 53, 116, 133
 Operational calibration gas cylinder 22, 51, 133
 Operational calibration gas flow 133
 Operational safety 16
 Operator of the device 18
 Ordinal number 122, 140
 Overheating 102
 Overlay keys 57, 58, 60
 Over-voltage protection 42
 Oxygen 13

P

Parameter
 - changes at the operation panel 89
 Parameterization (enSuite) 108, 112, 115
 - device 104, 105
 - transfer to device 115
 Particle filter 24, 27, 35, 36, 129
 Password 73, 87, 109, 120
 - change at the operation panel 89, 90
 Password protection 55
 Personal protection 42
 Point of functional earthing 43
 Post processing AFB 99, 109
 Potential equalization 41
 Power consumption 43, 135
 Power supply 12, 28, 44, 53, 54, 102, 135
 Power-LED 95
 Pressure exhaust tube 39
 Pressure of gases 34
 Pressure Regulator
 - manual flushing process 38
 Process dependent values 29
 Process gas 27, 140
 - connecting device with the line 40
 - inlet filter 130
 Process Gas
 - sample line connection 37
 Process gas connection 36
 Process gas flow 134
 Professional 7, 141
 Protection class 44
 Protective equipment 31
 Protective Extra Low Voltage 11, 141
 Protocol archive 74
 Protocol error 99
 PU 139
 Pulse output 49
 PW1/PW2 139

Q

Q2 AFB 109
 Q2 Control (displays) 69
 Q2 Deltas (display) 84
 Q2 device

- cleaning 126
 Q2 main display 78
 Q2 References (display) 84

R

RAM-load 64
 Range tests 126
 Read out archives 104
 Readout parameterization 104, 107
 Reboot 93, 115, 117
 Red color fonts (error) 29, 114
 Red text 66
 Red values 53
 Relative humidity 15, 31
 Remote control 81
 Remote operation panel 56, 57, 73, 81
 Repairs 9, 96, 129
 Repeatability 134
 Residual pressure Gas cylinder 39
 Response time 19, 36
 Restart 87
 Reverse polarity 42
 Ring memory 91
 Risk of corrosion 15
 RS485 47

S

Safety notes 9, 10, 27
 Safety Notes
 - opening housing 134
 Sample gas 140
 Sand protection 29, 32
 Sealing 51
 Secured parameter (display Info) 65
 Security Switch (SSW) 64, 82, 97, 139, 141
 Select a type of error 67
 Selectable points 59
 Seminar 55
 Sensor block operating pressure 25
 Sensor values (list) 68
 Serial interface 47
 Serial number 64, 135
 Service calibration 129
 Service calibration gas 133
 Service hotline 3, 9, 96
 Shut-off valve 36
 Signal 141
 Signal lights (LEDs) 29
 Software 131
 Software info (display) 65
 Software status Q2 65
 Software structure 61
 Software version 65
 Solenoid valve 24
 Spare parts 129
 Specialist 7, 9, 11, 141
 Staff 11
 Start delay 109, 141
 Station operator 11, 14, 18, 41, 101
 Status LED 29, 78, 141
 Status of enSuite parameters 114
 Status-LED 95
 Storage 30, 54
 Storage rooms 31
 Storage time 31
 Super user 109, 141
 Supply voltage 42, 102
 Surface temperature 15

Switch 41
 Switch on 101
 Symbols 7
 Synchronize system time 72
System Function Block (enSuite) 104
 System icon 70
 System time 70, 94, 97, 141
 System Time 119

T

Table archive data 121
 TB1/TB2 139
 Technical Data 131
 Technical features 19
 Technical help 9
 Temperature
 - at measurement conditions 52
 Temperature Sensor Block (TSB) 52
 Test mode 75, 103
 Test of screen 66
 Texts displayed on the device 96
 TH1 (Housing Temperature) 139
 Time 70
 Time controlled actions 119
 Time of day 61
 Time service 70
 Time service (device) 94
 Time Service (SFB) 109, 119
 Time setting 71
 Time stamp 91, 122, 141
 Time synchronization 71
 Time zone 70, 141
 TM1/TM2 139
 Touch screen 29, 56
 TP (Board temperature) 139
 Training 55
 Transportation of the device 30, 54
 Transportation protection of the device 31
 Troubleshooting 63, 96, 100
 TSB (Temperature Sensor Block) 25, 68
 Type plate of Q2 135

U

Uncertainty 134
 User 141
 - management 141
 -profile 141
 User archives 80
 User archives Main Display 80
 User archives Values 80
 User management 55, 109, 112, 120
 User name 73, 87, 89, 109
 Users 70
 Users Main display 72, 88

V

Valve block 141
 Verification 84, 109
 Verification (manually) 84
 Verification gas 27, 141
 Violation limits 98
 Virtual login (enSuite) 110
 Visual inspection 126
 Visualization (enSuite) 122

W

Warning 7, 9, 10

Warning messages 96, 141
Warranty conditions 3
Watchdog (signal) 97
Weight GasLab Q2 31
Weight of Q2 131
Wi (Net Wobbe index) 79
Wobbe index 20
Working step of device 77

Y

Year of manufacture 135

Z

Z (compressibility factor) 79

12.2 Figures

Figure 2.1: Locations for warnings.....	13
Figure 2.2: Example for warning label in English and French.....	13
Figure 3.1: Operating principle	20
Figure 3.2: Infrared measurement principle.....	21
Figure 3.3: TCD measuring method	21
Figure 3.4: General system setup.....	22
Figure 4.1: Overview of functional areas	23
Figure 4.2: Functional housing part	24
Figure 4.3: Gas passage during analysis function	25
Figure 4.4: Overview of connections	26
Figure 4.5: Interactive display.....	29
Figure 5.1: Dimensional drawing with optional sand cover	33
Figure 5.2: Definition of gas connections.....	35
Figure 5.3: Connection box with functional grounding	43
Figure 5.4: Earthing/grounding of housing for protection.....	43
Figure 5.5: Position of electrical entries.....	44
Figure 5.6: Connector pin assignment.....	46
Figure 5.7: Example LAN / Ethernet connection.....	47
Figure 5.8: Example RS485 connection	48
Figure 5.9: Example connection of the digital inputs	49
Figure 5.10: Example connection of the digital outputs	49
Figure 5.11: Example connection of the analog outputs.....	50
Figure 7.1: Interactive screen on the device	56
Figure 7.2: PC view of the remote operation panel with browser.....	57
Figure 7.3: Overview of display parts	57
Figure 7.4: Overlay keys local and remote	58
Figure 7.5: Buttons at the lower edge of the display.....	60
Figure 7.6: Branch points display "Home"	61
Figure 7.7: Display Q2 Not Ready	63
Figure 7.8: Display Info Q2.....	64
Figure 7.9: Display Info Device monitor.....	64
Figure 7.10: Display Info Software status	65
Figure 7.11: Displays and sub-displays Info Software info	65
Figure 7.12: Display Info Display test	66
Figure 7.13: Display Info License info.....	66
Figure 7.14: Display and kind of errors.....	67
Figure 7.15: Display error list main display	67
Figure 7.16: Display Q2 sensor values.....	68
Figure 7.17: Display Q2 control with Sub-displays Q2 calibration and Q2 verification.....	69
Figure 7.18: Display Q2 calibration data and display Q2 calibration gas.....	69
Figure 7.19: System display	70
Figure 7.20: Time service main display without / with NTP synchronization.....	70
Figure 7.21: Time service time synchronization.....	71
Figure 7.22: Display Time Service Date & Time with different time stamp formats	71
Figure 7.23: Display Time Service NTP overview (option)	72
Figure 7.24: User's main display without/with login	72
Figure 7.25: Display Error List Logbook	73
Figure 7.26: Display general audit trail overview	74
Figure 7.27: Display fiscal audit trail overview	74
Figure 7.28: Example audit trail details.....	74
Figure 7.29: Display I/O overview.....	75
Figure 7.30: Display Q2 I/O Ethernet I/F	75
Figure 7.31: Q2 main display (during start up).....	76

Figure 7.32: Q2 main display (factory parameterization)	76
Figure 7.33: Examples of the appearance of the basic display with 2 calculation standards	77
Figure 7.34: Q2 Standard A details.....	79
Figure 7.35: Q2 Standard B details.....	79
Figure 7.36: Display Archive Main display and Values	80
Figure 7.37: Display Modbus Main display and Modbus register.....	80
Figure 7.38: Displays in normal operation.....	81
Figure 7.39: Displays with logged in user	81
Figure 7.40: Displays while remote operation panel is active	81
Figure 7.41: Displays with logged in user and remote operation panel is active.....	81
Figure 7.42: Composition operational calibration gas	82
Figure 7.43: Operational calibration gas 1 confirm	83
Figure 7.44: Q2 calibration progress flushing calibration gas	83
Figure 7.45: Q2 Calibration progress gas 1	83
Figure 7.46: Q2 manual calibration ready.....	83
Figure 7.47: Display Q2 Deltas and References.....	84
Figure 7.48: References with input option.....	84
Figure 7.49: Display Q2 verification	85
Figure 7.50: Display Q2 confirm (verification gas)	85
Figure 7.51: Display Q2 verification is running.....	85
Figure 7.52: Display Q2 verification end	85
Figure 7.53: Display Q2 confirm (process gas).....	85
Figure 7.54: Drop-down list opened.....	86
Figure 7.55: Keypad shown	87
Figure 7.56: Login and logout states.....	88
Figure 7.57: User's main display with user logged in	89
Figure 7.58: User's main display password change.....	90
Figure 7.59: Display I/O with input option	93
Figure 7.60: Displays to update the system time on the device or on remote operation panel	94
Figure 7.61: Display I/O overview and board details.....	103
Figure 8.1: Bricks /enSuite.....	104
Figure 8.2: Example: navigation window and parameterization window	105
Figure 8.3: No connection was established	107
Figure 8.4: Connection has been interrupted.....	107
Figure 8.5: Dialog "Save as"	107
Figure 8.6: Example saved parameterization.....	107
Figure 8.7: Example device tree structure	108
Figure 8.8: Function "use virtual login".....	111
Figure 8.9: Example left and right part of the parameterization window	113
Figure 8.10: Example selections and reactions of the parameterization window	113
Figure 8.11: Example parameter can be switched.....	114
Figure 8.12: Example: export values in the parameter window.....	114
Figure 8.13: Example parameters during editing	114
Figure 8.14: Basic display editor.....	118
Figure 8.15: Navigation window Update date and time.....	119
Figure 8.16: Edit user dialog.....	120
Figure 8.17: Change password dialog	120
Figure 8.18: Configuration choose approval file.....	125
Figure 10.1: Metering ranges.....	134
Figure 10.2: Example position of main type plate	135
Figure 10.3: Example main type plate	135
Figure 10.4: Extra marks on the device	136